

*Simpson*<sup>®</sup>

**Hawk 3-Temperature  
H340  
4 Digit  
Advanced Digital Controller  
OPERATORS MANUAL**



**SIMPSON ELECTRIC COMPANY** 520 Simpson Avenue  
Lac du Flambeau, WI 54538-0099 (715) 588-3311 FAX (715) 588-3326  
Printed in U.S.A. Part No. 06-117489 Edition 5, 06/07  
Visit us on the web at: [www.simpsonelectric.com](http://www.simpsonelectric.com)

**About this Manual**

To the best of our knowledge and at the time written, the information contained in this document is technically correct and the procedures accurate and adequate to operate this instrument in compliance with its original advertised specifications.

**Notes and Safety Information**

This Operator's Manual contains warning symbols which alert the user to check for hazardous conditions. These appear throughout this manual where applicable, and are defined below. To ensure the safety of operating performance of this instruments, these instructions must be adhered to.

 Warning, refer to accompanying documents.

 Caution, risk of electric shock.



This instrument is designed to prevent accidental shock to the operator when properly used. However, no engineering design can render safe an instrument which is used carelessly. Therefore, this manual must be read carefully and completely before making any measurements. Failure to follow directions can result in a serious or fatal accident.

**Technical Assistance**

SIMPSON ELECTRIC COMPANY offers assistance Monday through Friday 8:00 am to 4:30 pm Central Time. To receive assistance contact Technical Support or Customer Service at (715) 588-3311.

Internet: <http://www.simpsonelectric.com>

**Warranty and Returns**

SIMPSON ELECTRIC COMPANY warrants each instrument and other articles manufactured by it to be free from defects in material and workmanship under normal use and service, its obligation under this warranty being limited to making good at its factory or other article of equipment which shall within one (1) year after delivery of such instrument or other article of equipment to the original purchaser be returned intact to it, or to one of its authorized service centers, with transportation charges prepaid, and which its examination shall disclose to its satisfaction to have been thus defective; this warranty being expressly in lieu of all other warranties expressed or implied and of all other obligations or liabilities on its part, and SIMPSON ELECTRIC COMPANY neither assumes nor authorizes any other persons to assume for it any other liability in connection with the sales of its products.

This warranty shall not apply to any instrument or other article of equipment which shall have been repaired or altered outside the SIMPSON ELECTRIC COMPANY factory or authorized service centers, nor which has been subject to misuse, negligence or accident, incorrect wiring by others, or installation or use not in accord with instructions furnished by the manufacturer.

**NOTES:**

**NOTES**

# Contents

1. INTRODUCTION .....	5
1.1 General Description .....	5
1.2 Specifications .....	5
2. DISPLAY AND KEYPAD CONTROLS .....	6
3. INSTALLATION AND PANEL CUTOUT .....	6
3.1 Mounting Requirements .....	6
3.2 Engineering Label Placement .....	7
4. REMOVING / INSTALLING OPTION MODULES .....	7
5. OPERATING THE KEYS .....	8
5.1 In Run Mode .....	8
5.2 In Program Mode .....	8
5.3 In Edit Mode .....	8
6. PROGRAMMING MENU .....	9
6.1 Relay Control .....	9
6.2 Display Control .....	10
6.3 Measurement Control .....	10
6.4 Output Control (If Present) .....	11
6.5 System Control .....	11
6.6 Password .....	12
7. TEMPERATURE INPUT CARDS .....	13
7.1 Relay Cards .....	13
7.2 Frequently Asked Questions .....	14
7.3 Power Supply Card .....	14
8. MENU FLOWCHART .....	16
9. MENU DETAIL .....	18
9.1 Relay Control (Sp1-Sp4) .....	18
9.1.1 Response .....	18
9.1.2 Delay .....	18
9.1.3 Latch .....	19
9.1.4 Alarm .....	19
9.2 Display Control .....	19
9.3 Output Control .....	20

20mA) When the display reaches 0 percent the analog output would be 4mA.

The limits can be moved or reversed (HI=0 and LO= 80.0), in this case when the display reads 0 , the analog output would be 20mA and when the display reads 80, the analog output would be 4mA.

The Fail Safe option (**FS**) controls the action of the analog output when the display goes into over-range (EEEE or -EEEE). In some cases, the low limit or high limit are reserved for error conditions. With set to 'HI', the output will run to the 20mA value when over-range or under-range occur. With failsafe set to 'LO', the output will run to 4mA at over-range or under-range. With failsafe 'Off', the output will go to the defined limit ends. (-EEEE would be 4mA and EEEE would be 20mA typically.)

The display banding, **band**, works from a different approach. The value entered is the amount of digit movement allowed before the display should be updated. With a band setting of 2, the value must move 2 counts up or down in the rightmost position as compared to the current display to cause the display to update.

**NOTE:** The two previous features can finely or coarsely stabilize the display and remove the pops and jitters typically found when monitoring a power line. The adjustment of this setting only filters what is displayed. The actual raw signal is evaluated against the setpoint and will go into alarm even if the display were set for maximum filtering and gave no indication of nearing the setpoint. Use hysteresis on delay in SP menu to slow relay action.

The **Brit**( Brightness) of the display is adjustable to allow for dimming in low light applications or for intensity matching with other equipment. The default is set to the brightest setting (5).

**ICE** (Zero or Null) Using ICE allows the user to grab a running offset and zero to it. A running offset can be useful for monitoring the tolerance to a value instead of the value, cancelling lead error in measurement or removing some signal difference in a measurement. Once ICE is enabled in the menu (ICE = ON), the device will wait until the user presses ▲ and ▼ . At that point, the unit will grab the current value and offset the display to zero. By choosing “hold” in the ICE menu the ICE value can then be saved to a more permanent location. No new ICE can be taken, but the value will not be lost if power fails.

**NOTE:** Be aware that introducing a ICE value will change the setpoint thresholds and erase any previous Hi Lo readings.

**HILO** (Min/Max) allows the user track the history of the readings on the display. By pressing ▲, the unit will momentarily display the highest value it has reached after last being reset. By pressing ▼, the unit will momentarily display the lowest value it has reached after last being reset.

## 9.3 Output Control

An optional analog outputs is available.

The analog output is a current or voltage that represents an equivalent range of signal on the input. Analog output can be purchased as 4-20mA DC out or 0-10V DC out. When installed, the Hawk 3 will sense the card and the menu will open the choices available to it.

Setting the limits (**LIM**). The ends of the analog output range (4 & 20 or 0 & 10) can be set or ‘pegged’ to and display value within the range of the meter.

Example: The Hawk 3 is purchased as a standard 200 volt meter. The analog output is configured, by default, for HI=100.0 and LO=0.

When the display reaches 100 volts, the analog output would be 20mA. When the display reaches 0 volts the analog output would be 4mA.

The Hawk3 is purchased as a process meter 4 – 20 mA input which will display 0-100 percent. The analog output is configured, by default, for HI=100.0 and LO=0. This means when the display reached 100 percent the analog output would be 20 mA. (Also, because this is a process meter the input should be

# 1. INTRODUCTION

## 1.1 General Description

The Simpson Electric Hawk 3 Advanced Digital Panel Meter/Controller has 4-digit display. All LEDs are 7 segment and offer 5 brightness levels. The high quality instrument has user programmable parameters that are all set from the front panel in easy to understand terminology. The display also shows activated set point indicators (up to four). The keypad buttons have audible and tactile feedback to prevent keystroke errors.

## 1.2. Specifications

	<i>Specifications</i>
<b>Display:</b>	
Type:	7-segment, red LED
Quantity:	4
Height:	0.56" (14.2mm)
Decimal Point:	None
Brightness:	Non Programmable 5 settings User Programmable
Over-range:	Display Reads EEEE Indicating Maximum Value
Under-range:	Display Reads -EEEE Indicating Minimum Value
Alarm Indicators:	4 LED indicators For up to 4 Independent Setpoints
Sensor Break:	Display reads EEEE (Burnout)
<b>Power Requirements:</b>	
AC Voltages:	85 to 250 VAC/120 VAC @ 7W
DC Voltages:	9 to 36V DC @ 10W
<b>Accuracy:</b>	All measurements are at 25° C and measured as percent of reading.

Unit Type	Accuracy	Temperature Range
RTD PT100	.2%. +/- 2 Count	-200°C to +200°C
J	.2%. +/- 2 Count	-100°C to +760°C
K	.2%. +/- 2 Count	-200°C to +1250°C
E	.2%. +/- 2 Count	-100°C to +800°C
T	.2%. +/- 2 Count	-200°C to +400°C

### Environmental

Operating Temperature.	0 to 50°C
Storage Temperature.	-10 to 60°C
Relative Humidity:	<85%
Ambient Temperature:	25°C
Temperature Drift:	±100 ppm/C° ±0.05dgt/°C
Warm up Time:	10 minutes

### Noise Rejection

NMRR:	60dB @ 50/60 Hz
CMRR:	100 db @ 50/60 Hz

### A to D Conversion

Technique:	Successive Approximation with oversampling
Sample Rate:	10 Conversions per second
Display Rate:	User Programmable from 1/minute - 8/second

## 2. DISPLAY AND KEYPAD CONTROLS

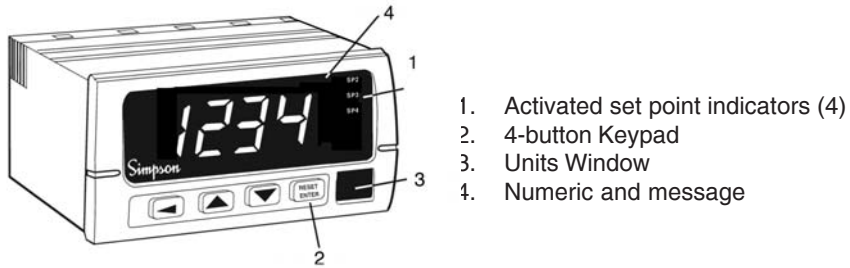

Figure 2-1

1. Activated set point indicators (4)
2. 4-button Keypad
3. Units Window
4. Numeric and message

## 3. INSTALLATION AND PANEL CUTOUT

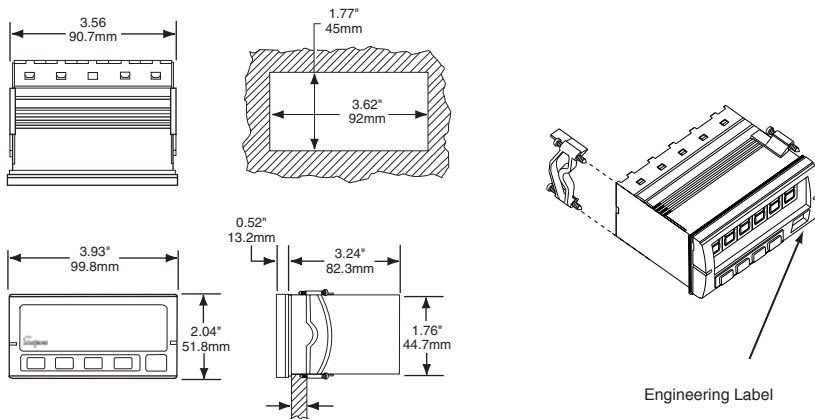

Figure 4-1. Installation and Panel Cutout

### 3.1 Mounting Requirements

The Hawk 3 Advanced Digital Controller 1/8 DIN counters require a panel cutout of 1.77" (45mm) high by 3.62" (92mm) wide. To install the counter into the panel cutout, remove the clips from the side of the meter. Slide the meter through the panel cutout, then slide the mounting clips back on the meter. Press evenly to ensure a proper fit.

seconds the alarm will trip and remain in alarm until the display drops below the setpoint for at least 2.5 seconds

### 9.1.3 Latch

When choosing **Ltch**, the relay output will latch immediately after crossing the setpoint. The unit can then only be unlatched with a front panel reset or a reset command from the RS-485 port.

**NOTE:** If the display is still beyond the setpoint threshold, the reset will have no effect and the unit will remain latched.

### 9.1.4 Alarm

The **Alr** mode allows choice between High, Low, or Off. The High Alarm means that the display value must be greater or equal to the setpoint to go into Alarm. The Low Alarm means that the display value must be less than or equal to the setpoint to go into alarm. The Off Alarm means that all features of this setpoint is disabled. No action will occur when display crosses a setpoint and the relays will revert to a normally de-energized state.

When selecting **St** (State) from the menu, the display will alternate between Stand the current setting.

To edit the setting press **RESET ENTER**. Otherwise press **▼** to move to the next choice.

If choosing **ND** (Normally De-energized) the relay will turn "on" the alarm condition. This is a typical configuration. The one and two-relay outputs will act as abeled; the normally closed contact will be closed until an alarm condition occurs, and the opposite is true for the normally open connection. The four-relay output only has the choice of normally open.

If choosing **NE** (Normally Energized) the relay will turn on at power up and remain on until in an alarm condition. This mode can be used to create a fail-safe condition or reverse the action of the four-relay configuration. In the fail-safe example, the relay output would be wired to protect some device during an alarm condition. During a power failure, the relay would be in the same position as though it were in alarm thus protecting a device that may be on a separate and possible active circuit.

## 9.2 Display Control

The next item that will appear in the menu is **Dctl** (Display Control). If this is the item to be edited press **RESET ENTER** otherwise press the down arrow **▼** to move to the next choice.

The display degrees, Deg, will allow you to select either °F or °C for the temperature indication. There is no need to change this value if you prefer the default °C indication.

The display refresh, **frsh**, will slow the numbers of updates to the display. This setting ranges from as fast as 480 updates per minute (8 updates per second) to as slow as 1 update per minute.

## 9. MENU DETAIL



### 9.1 Relay Control (Sp1-Sp4)

While in menu, all other operations are suspended.

The H340 has four setpoint parameters and up to four relays associated with those four setpoints. The setpoint LEDs on the display will light even if no relay is present for that setpoint.



To change the setpoint value, enter the menu by pressing ◀. If the password allows relay control, it will be the first menu to appear. The display will show the word “Sp1”. If this is the setpoint to be edited, press , otherwise press ▼ to move to the next choice. When editing Sp1, the display will alternate between Val-1 and a value. The “value” represents a threshold above or below the setpoint being set to alarm.

**NOTE:** Before editing this value, be sure that the decimal point is in the proper position. It is also recommended that any scaling or linearization be entered before setpoints are determined.

Press  to choose Val-1 as the setting to be edited. Notice that the far right digit has an alternating cursor. To change this digit, use ▲ or ▼. To move to the next digit, press ◀. When all changes to the value are complete, press  to confirm the change and save it to memory.

**NOTE:** Any power loss before confirming a change will lose the edited value. The menu will revert back to alternating between Val-1 and value. Press ▼ to move to the response setting.

#### 9.1.1 Response

The display will now show “Rsp.” To edit response, press , otherwise press ▼ to move to the next choice. When editing Rsp., the display will show Hyst, Dlay, or Ltch Flashing. Use ▲ or ▼ to choose the required response. Press  to confirm the choice. When choosing Hyst, the display will alternate between Hyst and the current value.

To edit the value, press . Otherwise press ▼ to move to the next choice. Hysteresis will be used above and below the setpoint in equal amounts. The value represents a percentage of the setpoint. For example: If the setpoint is set to 100.00 with a high alarm and the hysteresis is set for 8.5%, the alarm will not turn on until the reading on the display reaches 108.50. Once tripped, the alarm will not turn off until the display reaches 91.50.

#### 9.1.2 Delay

When choosing Dlay, the display will alternate between Dlay and current value. To edit the value press . Otherwise press q to move to the next choice. Dlay will be used above and below the setpoint in equal amounts. The value represents the amount of delay in seconds. For example, if the setpoint is again configured for high alarm and Dlay is set for 2.5 seconds the display crosses the setpoint value and a timer begins to count off the 2.5 seconds before the alarm trips. If, during those 2.5 seconds the value falls below the setpoint, no action will be taken. When the unit successfully counts off 2.5

## 3.2 Engineering Label Placement

If the engineering unit label needs replacing, place the tip of a ballpoint pen into the small hole at the base of the engineering label in the bezel. Slide the label up until it pops out. Grasp and remove. Slide the new label half the distance in, then use the ballpoint pen to slide it down into place.

## 4. REMOVING / INSTALLING OPTION MODULES



Shut off power before removing or installing any option module.



1. Remove module from case by inserting a screwdriver into tab slot opening at top of input module (see Figure 5-1). Apply pressure to release module from case. Repeat procedure for tab located on underside of module and then slide module away from case.
2. Refer to appropriate sections to configure switches or jumpers for proper operation.

Figure 5-1. Removing Option Module

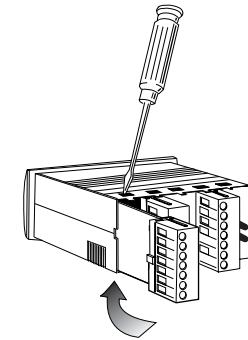

3. Install module by carefully aligning module edges with slots in case and pressing forward until tabs (on top and bottom) engage.

## 5. OPERATING THE KEYS

### 5.1 In Run Mode

- ◀ = Enters the Program Menu
- ▲ = Displays the Maximum Value (if enabled). Press ▲ and hold while pressing **RESET ENTER** to clear max. value.
- ▼ = Displays Minimum Value, if enabled. Press ▼ and hold while pressing to clear min. value
- RESET ENTER** = Resets Latched Relays (If any)
- ▲ and ▼ = Sets Zero/ICE Value (if enabled). Also clears Minimum and Maximum Values

### 5.2 In Program Mode

- ◀ = Enters the Edit Mode. Flashing cursor shows value to edit. (Numeric Values only)
- ▲ = Scrolls “UP” through menu choices
- ▼ = Scrolls “DOWN” through menu choices
- RESET ENTER** = Selects a menu or submenu to edit.

### 5.3 In Edit Mode

- ◀ = Moves Edit Cursor to the left. Flashing cursor shows value to edit (Numeric Values Only)
- ▲ = Increases Numeric Value or Scrolls “UP” through sub-menu choices.
- ▼ = Decreases Numeric Value or Scrolls “DOWN” through sub-menu choices.
- RESET ENTER** = Confirms and Saves your new setting.

**IMPORTANT:** After editing parameters, exit programming menu completely. If this step is not followed, changes will not be saved.

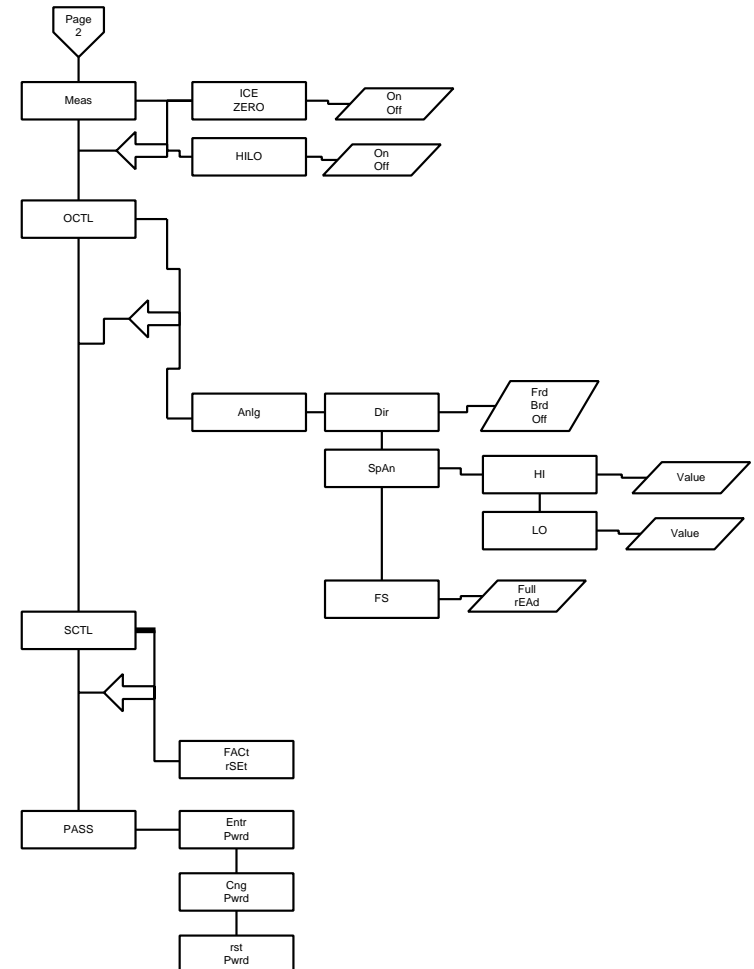

## 8. MENU FLOWCHART

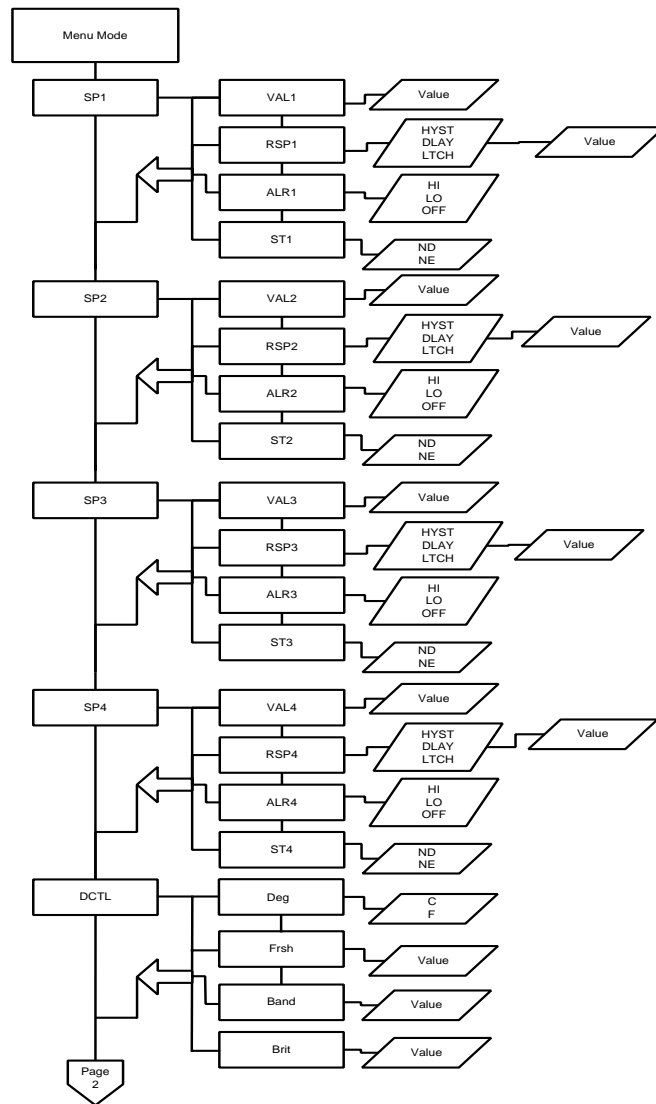

## 6. PROGRAMMING MENU

Depending on the operator's password rights, some choices shown below be unavailable. Use caution when changing values "on the fly" because relay changes are immediate upon exiting menus. While in local menu, RS-485 communications will halt to avoid command conflict. While in local or remote menu, relay and alarm operation are suspended. The local or remote menu will "time out" in two minutes and resume normal operation.

### 6.1 Relay Control

SP1 Set Point #1 & Relay #1 (if present)			
	Val-1	Value	10000*
	Rsp1 (Response 1)	Hyst Dlay* Ltch	0* to 29.9% 0* to 60.00 Seconds (0.10*) Active
	Alr-1 (Alarm 1)	HI* LO OFF	
	St-1 (State when not in Alarm)	ND* NE NE	De-energized Energized or De-energized

SP2 Set Point #2 & Relay #2 (if present)			
	Val-2	Value	
	Rsp2 (Response 2)	Hyst Dlay* Ltch	0* to 29.9% 0* to 60.00 Seconds (0.10*) Active
	Alr-2 (Alarm 2)	HI* LO OFF	
	St-2 (State when not in Alarm)	ND* NE	

SP3 Set Point #3 & Relay #3 (if present)			
	Val-3	Value	
	Rsp3 (Response 3)	Hyst Dlay* Ltch	0* to 29.9% 0* to 60.00 Seconds (0.10*) Active
	Alr-3 (Alarm 2)	HI LO Off*	
	St-3 (State when not in Alarm)	ND* NE	

\*Factory Reset Default Values

SP4 Set Point #4 & Relay #4 (if present)			
	Val-4	Value	10000*
	Rsp4 (Response 4)	Hyst Dlay* Ltch	0* to 29.9% 0* to 60.00 Seconds (0.10*) Active
	Alr-3 (Alarm 4)	HI* LO OFF	
	St-4 (State when not in Alarm)	ND* NE	

\*Factory Reset Default Values

## 6.2 Display Control

DctL		
	deg(rees)	C*(Celsius) F (Fahrenheit) Fixed based on RTD or TC
	Frsh (Refresh)	Value - 1 to 480 updates per minute (240*)
	Band	Value - 0* to 99 counts from current value.
	Brit (Brightness)	▲ and ▼ arrows move LED brightness through 5 levels as indicated on display. (5* full brightness)

\*Factory Reset Default Values

## 6.3 Measurement Control

MEAS		
	(Zero) ICE (Point)	Off* On - Temporary TC Correction (Until power cycle) Hold - Permanent TC Correction
	HILO (Minimum/Maximum) Display Enable	Off* On

The hold feature is used to freeze the display. When the contacts are shorted, the display will "Hold" the last reading until the short is removed. It is recommended that a mechanical switch or relay be used to activate the hold circuit, solid state relays may give unexpected results. The hold circuit cannot be externally powered.



No terminal can be above earth ground by more than 250Vrms. An external fuse is recommended for safe operation, for AC supply, Slow Blow fuse at .25A, Littlefuse Part No. 313.250 or equal. For DC supply Slow Blow fuse at 1.25A, Littlefuse Part No. 3131.25 or equal.



Hazardous voltages may be present. Disconnect power before making or removing connections.

The relay cards are directly related to any alarms that occur on the Hawk 3. The single relay is a “Form C” relay that activates in relationship to “SP1”. The dual relay is a “Form C” relay that activates in relationship to “SP1” & “SP2”.

The quad relay is a “Form A” relay that activates in relationship to “SP1” through “SP4”.

**NOTE:** “SP3” and “SP4” connections share a common.



All relay contacts are rated at 250VAC @ 5 amp maximum. The rating of the relay contact is intended for resistive circuits only. Use a snubber circuit to protect the contacts from inductive loads.

## 7.2 Frequently Asked Questions

### What is a Form A or Form C relay?

The form A relay is a 1 contact switch that is either closed or open. The form C relay has 2 contacts, one of which will be closed and one open. With the factory defaults used, N.O. on the relay means normally open when the Hawk 3 is **not** in alarm. N.C. means normally closed when the Hawk 3 is **not** in alarm.

### What does N.D. and N.E. do to the relay?

The effect of the relay can be reversed by setting the relay action to N.E. (normally energized) in the menu. When the Hawk 3 is **not** in alarm, the N.C. contact will now be open and the N.O contact will be closed. Setting the alarm response back to N.D. (normally de-energized) will put the contacts back to their default state.

## 7.3 Power Supply Card

Universal AC Supply    3-1/2 Digit 120 VAC Supply    DC to DC Supply

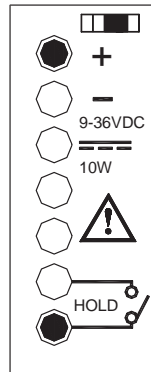
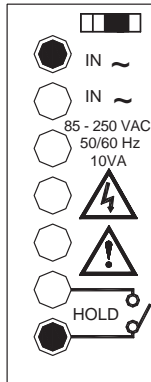
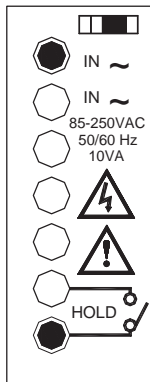

The AC power cards are meant to operate from standard 50/60 Hz line power. The DC to DC power card is an isolated supply that can operate between 9 and 32 volts DC.

## 6.4 Output Control (If Present)

OctL		
ALog out		
	LIM	HI (electrical limit) (100*)
		Lo (electrical limit) (0*)
	FS (Fail safe) (Overrange or Underrange)	HI (move to 20mA)
		LO (move to 4mA)
		Off*



## 6.5 System Control

(The process meter will have pre-loaded coordinates)

Sctl		
	FACT/rSET (Factory Reset)	Reset (Selecting this item will reset the device to default values and return to menu)

## 6.6 Password

Pass (Password)		
	000*	Full Access.
	001 to 200	No access to scale or factory reset.
	201 to 400	No access to scale, factory reset or measurement control.
	401 to 600	No access to scale, factory reset, measurement control or output control.
	601 to 800	No access to scale, factory reset, measurement control, output control or relay control.
	801 to 999	No access except password entry
	-999	Keypad lockout. All future key strokes will be ignored. All setting changes must come from RS-485 port. This choice is available only if the RS-485 card is present and configured for "Full".
CHG		
	<b>Nu-pas (New Password)</b>	Change the password to a new value. This is available only after successfully entering the current password or if the password is set to 000.

**NOTE:** If you forget your password, turn power off in unit, press and hold the ▼ key and the  key. Turn power on and wait until the display reads "noPas" then press the  key again to reset password to 000.

\* Factory Reset default value

## 7. TEMPERATURE INPUT CARDS

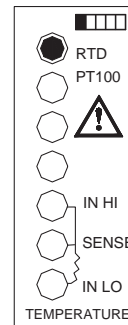

**RTD PT100:** The resistance input card has been configured to track the characteristics of a PT100 sensor.

Lead length error can be cancelled out by bringing the sensor to 0 C (ice point) and using the "ICE" command to zero the meter. (Remember to move the ICE capture from the "On" to "Hold" in order to retain the data.)

Lead length error can also be cancelled using the guard wire.

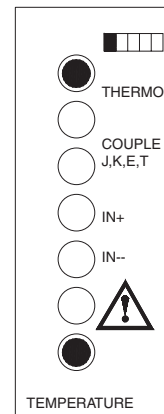

**7.2 J, K, E, T Thermocouple:** The thermocouple input card contains all the response information needed to read a J type or K type thermocouple.

Lead length error can be cancelled out by bringing the sensor to 0 C (ice point) and using the "ICE" command to zero the meter. (Remember to move the ICE capture from "On" to "Hold" to retain the data.)



Never apply a voltage or current to these inputs as damage will occur.

## 7.1 Relay Cards

### Single Relay

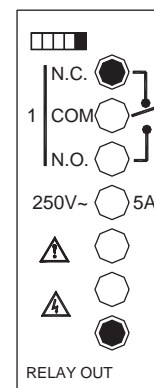

### Dual Relay

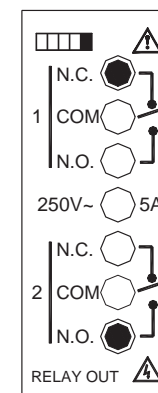

### Quad Relay

