



Falcon F35 Series Digital Panel Meter

- Full 3-1/2 Digit, Bright Red 0.56" (14.2mm) Display
- Broad Range Display Scaling
- Short 2.94" (74.7mm) Deep, 1/8 DIN Case
- Screw Terminal Connector for Easy Installation
- Four User-Settable Ranges: 200 μ A, 2mA, 20mA, 200mA
- Two Factory-Settable Ranges: 2A, 5A
- User-Selectable Decimal Point
- Average Responding and TRMS Measurement Ranges
- Optional Isolated 9-32VDC Power Supply



The Falcon Series digital indicators are premium quality 1/8 DIN meters for industrial applications. All Falcon units feature selectable decimal point from the terminal block and display scaling, providing wide application flexibility. In addition, most signal input ranges are easy to change with jumpers on the main board. The Falcon has a 0.56" bright red LED display for high visibility.

Compactly designed for applications requiring minimal rear panel depth, the Falcon fits a standard 1/8 DIN panel cut-out (91.9mm x 45mm) and requires less than 3" behind the panel. A screw terminal connector is a standard feature for easy wiring of the power supply and signal input connections.

Installation and Panel Cutout

Mounting Requirements
The Falcon series 1/8 DIN indicators require a panel cutout of 1.77" (45mm) high by 3.62" (91.9mm) wide. To install the Falcon into a panel cutout, remove the clips from the side of the meter. Slide the meter through your panel cutout, then slide the mounting clips back on the meter. Press evenly to ensure a proper fit.

Engineering Label Placement
If replacement of the engineering unit label is required, place the tip of a ball-point pen into the small hole at the base of the engineering label in the bezel. Slide the label up until it pops out. Grasp and remove. Slide the new label half the distance in, then use the ball-point pen to slide it down into place.

Specifications

DISPLAY

Type: 7-segment, red LED
Height: 0.56" (14.2mm)
Decimal Point: 3-position programmable, internally or on the terminal block
Overrange indication: most significant digit = "1"; other digits blank
Polarity: Automatic, with "-" indication, "+" indication implied

POWER REQUIREMENTS

AC Voltages: 120 or 220VAC, ±10%
 50/60Hz
DC Voltages: 9-32VDC, ±1%
Power Consumption: 3VA

ACCURACY @ 25°C

±1% of reading ±5 counts (45Hz - 1kHz)

ENVIRONMENTAL

Operating Temperature: 0 to 55°C
Storage Temperature: -10 to 60°C
Relative Humidity: 0 to 85% non-condensing

Temperature Coefficient:

(±0.1% of input ± 0.5 count)/°C
Warm-up Time: Less than 15 minutes
Response Time: Less than 3 seconds

NOISE REJECTION

NMRR: 50dB, 50/60Hz
CMRR: (w/1KV unbalanced @ 60Hz): 90dB min.

ANALOG TO DIGITAL CONVERSION

Technique: Dual slope integration

Rate: 3 samples per second, nominal

MECHANICAL

Bezel: 3.78" x 1.89" x .51"
 (96 x 48 x 13mm)
Depth: 2.94"(74.7mm)
Panel Cutout: 3.62" X 1.77"

(91.9 x 45mm 1/8 DIN)

Case Material: 94V-1, UL rated Noryl®

Weight: 9.0oz (255.1g)

INPUTS: AC/AC TRMS Current

Input Range	Display Resolution	Maximum Input	Voltage Drop
200µA	100nA	10mA	200mV
2mA	1µA	40mA	
20mA	10µA	100mA	
200mA	100µA	500mA	
2A	1mA	2.2A	
5A	10mA	5.2A	

Wiring Diagram

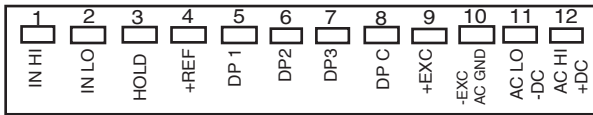

Input Signal: Connect the signal to be monitored to the IN HI and IN LO terminals. IN HI is terminal #1, IN LO is terminal #2.

Supply Power: Connect the supply power to terminals #11 and #12. Note that if AC power is supplied, terminal #11 is for Neutral, and terminal #12 is for Hot. If DC power is used, terminal #11 is for -DC, and #12 is for +DC.

Display Hold: This feature allows you to hold the displayed value indefinitely. A remote switch can be used to make the connection. To activate the display hold, short pins #3 and #4 (Hold and +REF). This connection must be kept isolated from other circuitry. To hold multiple units, separate poles of the switch must be used to maintain the isolation.



These instruments are designed for maximum safety to the operator when mounted in a panel according to instructions. They are not to be used unmounted or for exploratory measurements in unknown circuits.



Before switching the instrument on, make sure the supply voltage matches the power source required of the instrument as indicated on the hook-up label affixed to the instrument.

Decimal Point Selection

From terminal block: The decimal point can be set from the rear screw terminal block by connecting the appropriate decimal point (DP 1, 2, 3) to the DPC terminal. The J105 jumper block must be in the D position (see diagram under "From front panel.")

Decimal Point	Connect
1.999	DP C to DP1
19.99	DP C to DP2
199.9	DP C to DP3
1999	No Decimal

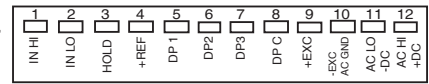

From front panel (For 200µ, 2mA, 20mA, 200mA input range only):

The decimal point can also be selected by removing the front bezel from the meter. Move the J105 jumper block across the correct letter.

Decimal point selection is done at the rear screw terminal block for the 2A and 5A input range units.

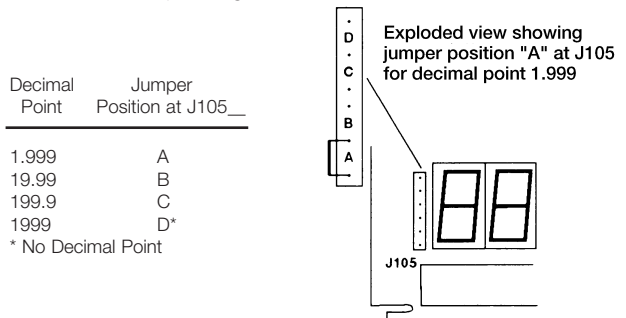

Current Range Selection

All Falcon Indicators are configured initially per the customer specifications. Range changes can be accomplished as follows:

Disconnect power from the unit. Remove the unit from the panel. Remove the front bezel by inserting slotted screwdriver in the vertical slots on either side of the bezel and then turning to pry the bezel off. Unscrew the two Phillips head screws at either side of the circuit board. Finally, push on the green connector assembly in the back of the unit to slide the main circuit board out from the meter. Change jumpers according to the chart below.

Note: If a new range is selected, the calibration procedure must also be performed.

Input Range	J102	J106	JU101	JU102
200µA	A	R	A	No
2mA	B	R	A	No
20mA	D	R	A	No
200mA	E	R	A	No

If you need to change a Falcon from (or to) a 2 amp or 5 amp unit, please consult the factory or an Authorized Service Center.

Note: JU101 and JU102 are hard wire jumpers, and are removed by cutting them. Resoldering the JU jumpers is not recommended. If this is required, or if a function is to be changed (from volts to current), Simpson recommends returning the Falcon to the factory or an Authorized Service Center. After moving the jumpers to the desired location, put the Falcon back together and install in your panel, or proceed to calibration.

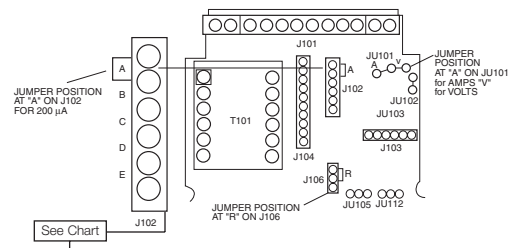

Display Scaling

The Falcon can be easily scaled for a broad range of engineering units. The meter may be scaled up to two times, or down to 1/5 the value of the input.

- 1) Remove the front bezel with a small screwdriver.
- 2) Apply the full scale input to the meter.
- 3) Adjust the potentiometer VR101 located on the right side the display board to the desired scaled value.
- 4) Replace the bezel carefully. A card of labels is provided for alternative engineering units, such as percent.

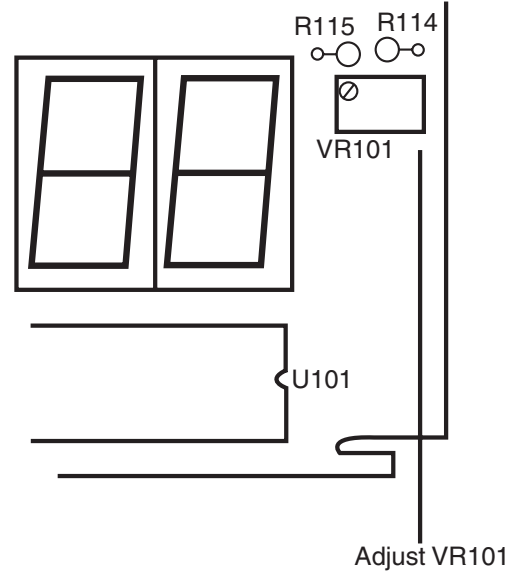

Calibration



The following procedure requires opening the unit and removing the top cover with the power ON. Use an insulated screwdriver and extreme caution when making these adjustments. It is advisable to have an Authorized Service Center perform this operation, or return the Falcon to the factory.

The Falcon is calibrated at the factory per order. If you changed the range and have moved the jumpers, your Falcon will need to be recalibrated.

- 1) Remove the bezel with a small screwdriver.
- 2) Short input terminals #1 and #2 (IN HI and IN LO) and adjust potentiometer RV1 on AC Input card until display reads 0 ± 1 count.
- 3) Apply an input signal to terminals #1 and #2, and adjust potentiometer VR101 until the display indicates the value of the signal. See diagram in Display Scaling.
- 4) Reassemble the meter and install it in your panel.

Located on the AC Input card

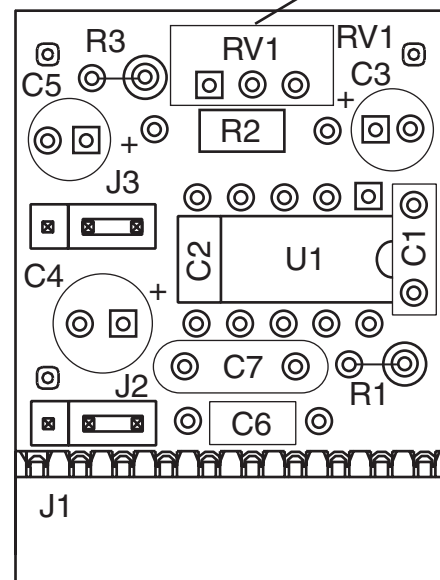

Application Example

A plant manager needs to monitor the current draw of two machines from one AC power source. The first machine is rated at 200mA, and the second machine is rated at 75 amps.

The first machine can be monitored with a Falcon 200 ACmA meter. The meter is installed in series between the source and the load. No additional scaling of the input is required.

The second machine requires a 75/5 amp Donut Current Transformer and a Falcon 5AC amp meter.

The meter needs to be scaled before it is installed in the panel. A 5 amp signal must be applied to the Falcon (full strength signal from the Donut Transformer). Change decimal point to 199.9 by connecting DPC to DP3 on rear terminal block. Next, remove

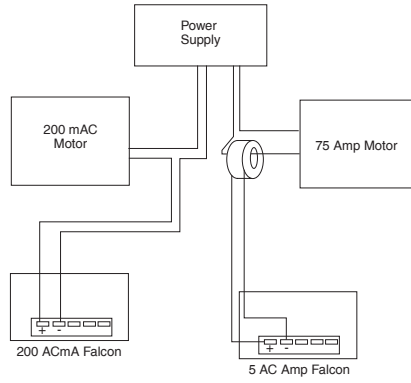

the front bezel. Adjust potentiometer VR101 until the display indicates 75.0 (amps) when the 5 amp signal is on. Replace the bezel, and remove the signal. The transformer is installed on one of the legs of the motor

to be monitored. The meters are installed into the panel, and are ready to operate.

Ordering Information

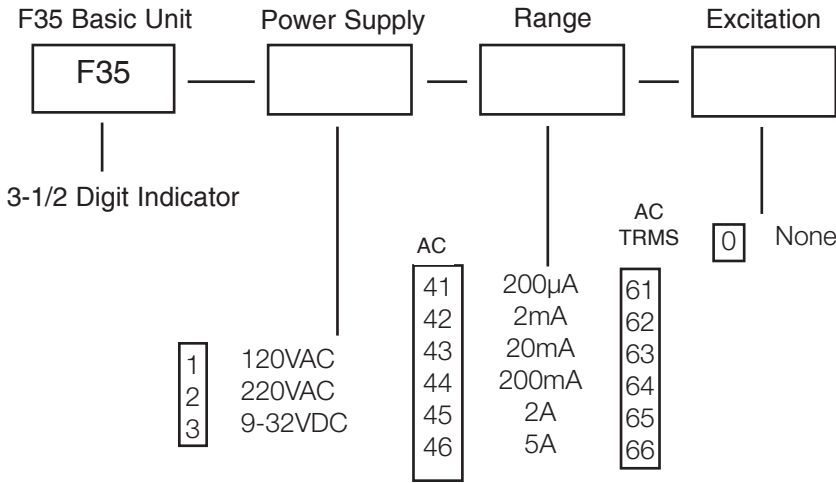

Safety Symbols



The WARNING sign denotes a hazard. It calls attention to a procedure, practice, or the like, which, if not correctly performed or adhered to, could result in personal injury.



The CAUTION sign denotes a hazard. It calls attention to an operating procedure, practice, or the like, which, if not correctly adhered to, could result in damage to or destruction of part or all the instrument.

Accessories

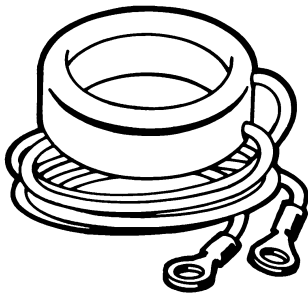

Donut Current Transformers enable the Falcon to monitor AC current up to 1999 amps. The Donut (also known as a "Toroid") is placed around one of the legs of the device being monitored, and emits up to a 5 amp signal. The Falcon can be scaled to accurately display the current being monitored.

Each Donut comes with 2' long secondary leads, and is rated at 2VA.

Ordering Information

Range/Amps		Catalog Number
Primary	Secondary	
50	5	01293
75	5	01306
100	5	01297
150	5	01298
200	5	01299
250	5	01313
300	5	01300
400	5	01305
500	5	01301
600	5	02303
750	5	02459
1000	5	02304

Input	Current Transformer	Dec. Point Position	Range of Reading
20.0A	5A	DP3	20.0A
25.0A	5A	DP3	25.0A
50.0A	5A	DP3	50.0A
75.0A	5A	DP3	75.0A
100.0A	5A	DP3	100.0A
200A	5A	None	200A
250A	5A	None	250A
300A	5A	None	300A
400A	5A	None	400A
500A	5A	None	500A
600A	5A	None	600A
750A	5A	None	750A
1000A	5A	None	1000A
For the following inputs, replace jumper R114 with a 63.4K±1% resistor (see Display Scaling)			
15.00A	5A	DP3	15.00A
150.0A	5A	DP3	150.0A
1200A	5A	None	1200A
1500A	5A	None	1500A
1999A	5A	None	1999A