

*Simpson*<sup>®</sup>

**2867 and 2868 (DC Measuring)  
2869 and 2870 (AC Measuring)  
3½ Digit Panel Instruments  
INSTRUCTION MANUAL**



## About this Manual

To the best of our knowledge and at the time written, the information contained in this document is technically correct and the procedures accurate and adequate to operate this instrument in compliance with its original advertised specifications.

## Notes and Safety Information

This Operator's Manual contains warning headings which alert the user to check for hazardous conditions. These appear throughout this manual where applicable and are defined below. To ensure the safety of operating performance of this instrument, these instructions must be adhered to.



Warning, refer to accompanying documents.



Caution, risk of electric shock.

## Technical Assistance

SIMPSON ELECTRIC COMPANY offers assistance Monday through Friday 8:00 am to 4:30 pm Central Time. To receive assistance contact Technical Support or Customer Service at (715) 588-3947.

Internet: <http://www.simpsonelectric.com>

## Warranty and Returns

SIMPSON ELECTRIC COMPANY warrants each instrument and other articles manufactured by it to be free from defects in material and workmanship under normal use and service, its obligation under this warranty being limited to making good at its factory or other article of equipment which shall within one (1) year after delivery of such instrument or other article of equipment to the original purchaser be returned intact to it, or to one of its authorized service centers, with transportation charges prepaid, and which its examination shall disclose to its satisfaction to have been thus defective; this warranty being expressly in lieu of all other warranties expressed or implied and of all other obligations or liabilities on its part, and SIMPSON ELECTRIC COMPANY neither assumes nor authorizes any other persons to assume for it any other liability in connection with the sales of its products.

This warranty shall not apply to any instrument or other article of equipment which shall have been repaired or altered outside the SIMPSON ELECTRIC COMPANY factory or authorized service centers, nor which has been subject to misuse, negligence or accident, incorrect wiring by others, or installation or use not in accord with instructions furnished by the manufacturer.

This manual represents your meter as manufactured at the time of publication. It assumes standard software. Special versions of software may be fitted, in which case you will be provided with additional details.

The apparatus has been designed and tested in accordance with EN 61010-1, "Safety Requirements for Electrical Equipment for Measurement, Control and Laboratory Use." This operating guide contains information and warnings that must be followed by the user to ensure safe operation and to maintain the apparatus in a safe condition.

We reserve the right to make changes and improvements to the product without obligation to incorporate these changes and improvements into units previously shipped.

**SHOCK HAZARD:** As defined in American National Standard, C39.5, *Safety Requirements for Electrical & Electronic Measuring & Controlling Instrumentation*, a shock hazard shall be considered to exist at any part involving a potential in excess of 30 volts RMS (sine wave) or 42.4 volts DC or peak and where a leakage current from that part to ground exceeds 0.5 milliamperes, when measured with an appropriate measuring instrument defined in Section 11.6.1 of ANSI C39.5.

**NOTE:** The proper measuring instrument for the measurement of leakage current consists essentially of a network of a 1500 ohm non-inductive resistor shunted by a 0.15 microfarad capacitor connected between the terminals of the measuring instrument. The leakage current is that portion of the current that flows through the resistor. The Simpson Model 229-Series 2 AC Leakage Current Tester meets the ANSI C39.5 requirements for the measurement of AC leakage current and can be used for this purpose. To measure DC Leakage current, connect a 1500 ohm non-inductive resistor in series with a Simpson 0-500 DC .microammeter and use this as the measuring instrument.

# Contents

1. INTRODUCTION .....	5
1.1 General .....	5
1.2 Technical Data .....	5
1.3 Theory of Operation .....	9
2. INSTALLATION .....	10
2.1 Safety Precautions .....	10
2.2 Panel Mounting Instructions .....	10
2.3 Power Source Requirements and Connections .....	11
3. SERVICING INSTRUCTIONS .....	13
3.1 Case and Front Cover Removal .....	13
3.2 Line Fuse Replacement (2867/2869 only) .....	13

# 1. INTRODUCTION

## 1.1 General

Models 2867 through 2870 (hereafter referred to by model number or the Instrument) are 3½-digit, panel-mounted instruments. Models 2867 and 2868 provide visual indication for either DC voltage or DC current measurements, while Models 2869 and 2870 provide measurement of AC voltage or AC current.

The Models 2867 and 2869 can be used as self-contained, panel-mounted units, operating from either a 120 or 240 volt AC, 50 to 400Hz power source. The Models 2868 and 2870 are designed to operate from a 5VDC power source. These Instruments feature solid-state light-emitting diode (LED) display, automatic polarity selection and indication, automatic zeroing, excellent temperature characteristics, high input resistance (for DC voltage models), fast response time, and automatic out-of-range indication. These Instruments, which provide high reliability and compact design, use a single Large-Scale-Integration (LSI) module for the analog-to-digital conversion circuitry.

These Instruments are especially suited for system-oriented application. The versatility of AC line or DC operation and 200mV full range sensitivity allow each Instrument to be used as a direct replacement for an analog type instrument. This feature makes it convenient to convert existing instruments or systems from analog to digital display and, at the same time, improve the performance of a system. Models 2867 and 2868 or Models 2869 and 2870 are each available in nine configurations, four voltage ranges and five current ranges as shown in Table 1 and Table 2.

**NOTE:** This Operator's Manual contains information essential to the operation of this Instrument. Therefore, keep it in a convenient place and use for reference as required.

## 1.2 Technical Data

The following table (Table 1) lists the data for Models 2867 and 2868 Instruments. Table 2 lists the data for Models 2869 and 2870.

*Table 1-1. Technical Data for Models 2867 and 2868*

### 1. FULL SCALE RANGES:

DC VOLTAGE:

Range	Maximum Indication	Input Resistance	Overload Protection	Catalog Numbers	
				Model 2867	Model 2868
200mV	±199.9mV	≥100MΩ		24620	24640
2V	±1.999V	≥100MΩ	250V	24621	24641
20V	±19.99V	≥ 10MΩ	All	24622	24642
200V	±199.9V	≥ 10MΩ	Ranges	24623	24643

DC CURRENT:

Range	Maximum Indication	Input Resistance	Maximum Overload Protection	Catalog Numbers	
				Model 2867	Model 2868
20μA	±19.99μA	250V	20mA	24624	24644
200μA	±199.9μA		20mA	24625	24645
2mA	±1.999mA	Ranges	20mA	24626	24646
20mA	±19.99mA		100mA	24627	24647
200mA	±199.9mA		1A	24628	24648

2. ACCURACY: ±(0.1% of input + 1 count) at reference conditions.
3. TEMPERATURE COEFFICIENT: ±(0.01% of input + 0.05 count) per °C from 0°C to +55°C.
4. SENSITIVITY: 100μV for 200mV unit; 10nA for 20μA unit.
5. RESOLUTION: One part in 2000.
6. INPUT BIAS CURRENT: 10pA maximum at reference conditions.
7. FULL RANGE STEP RESPONSE: (to rated accuracy) 1 second.
8. NORMAL MODE REJECTION: 50dB minimum at 60 Hz.
9. COMMON MODE REJECTION: (with 1kΩ unbalance at 60 Hz) 90dB minimum (Model 2867 only).
10. RATED CIRCUIT-TO-GROUND VOLTAGE\*: (MAXIMUM COMMON MODE VOLTAGE)
  - Model 2867: 250VDC between either input terminal and power line ground.
  - Model 2868: -4.0 to +4.5VDC between the common (-) input terminal and the power source common (5VDC return)

\*The maximum voltage, with respect to ground, which may safely and continuously be applied to the circuit of an instrument.

11. CONVERSION TECHNIQUE RATE: Dual-Slope integration. 3 samples per second, nominal.
12. DISPLAY TYPE: 7-segment, light-emitting diodes with 0.56" high numerals.
  - NUMBER OF DIGITS: 3 full digits plus overrange "1" digit.
  - POLARITY: Automatic, with "-" indication; "+" indication implied.
  - OUT-OF-RANGE: All digits blank, except "1" digit lit.

DECIMAL POINT: Jumper selectable.

13. POWER REQUIREMENTS:

- Model 2867: 120 or 240VAC ±10%, 50 Hz to 400 Hz, 5VA.
- Model 2868: 5VDC, ±5% at 200mA.

14. TEMPERATURE RANGE:

- OPERATING: 0°C to +55°C.
- STORAGE: -40°C to +60°C.

15. RELATIVE HUMIDITY:

0 to 85%, non-condensing.

16. REFERENCE CONDITIONS:

- TEMPERATURE: 23°C ±2°C.
- ATMOSPHERIC PRESSURE: 575 to 800 mmHg.
- RELATIVE HUMIDITY: 30 to 60%

17. WARM-UP TIME:

Less than 15 minutes at reference conditions.

Table 1-2. Technical Data for Models 2869 and 2870

1. FULL SCALE RANGES: (Average responding, calibrated for RMS reading of sine wave.)

AC VOLTAGE:

Range	Maximum Indication	Input Resistance	Overload Protection	Catalog Numbers	
				Model 2869	Model 2870
200mV	±199.9mV	≥100MΩ	250V rms	24630	24650
2V	±1.999V	≥ 10MΩ		24631	24651
20V	±19.99V	≥ 10MΩ	All	24632	24652
200V	±199.9V	≥ 10MΩ	Ranges	24633	24653

AC CURRENT:

Range	Maximum Indication	Voltage Drop	Maximum Input Current	Catalog Numbers	
				Model 2869	Model 2870
20μA	±19.99μA	250V rms	20mA	24634	24654
200μA	±199.9μA		20mA	24635	24655
2mA	±1.999mA	All	20mA	24636	24656
20mA	±19.99mA	Ranges	100mA	24637	24657
200mA	±199.9mA		1A	24638	24658

2. ACCURACY: 45Hz to 1kHz ±(1.0% of input + 5 counts) at reference conditions.

3. TEMPERATURE COEFFICIENT:

±(0.1% of input) per °C from 0°C to +55°C.

4. SENSITIVITY:

100μV for 200 mV unit; 10 nA for 20μA unit.

5. RESOLUTION:	One part in 2000.
6. INPUT BIAS CURRENT:	100pA maximum at reference conditions.
7. FULL RANGE STEP RESPONSE: (to rated accuracy)	3 seconds
8. CREST FACTOR:	Greater than 3:1 at full scale.
9. RATED CIRCUIT-TO-GROUND VOLTAGE*: (MAXIMUM COMMON MODE VOLTAGE)	
Model 2869:	250VDC between either input terminal and power line ground.
Model 2870:	-4.0 to +4.5VDC between the common (-) input terminal and the power source common (5VDC return).

\*The maximum voltage, with respect to ground, which may safely and continuously be applied to the circuit of an instrument.

10. CONVERSION:	
TECHNIQUE:	Dual-Slope integration.
RATE:	3 samples per second, nominal.
11. DISPLAY:	
TYPE:	7-segment, light-emitting diodes with 0.56" high numerals.
NUMBER OF DIGITS:	3 full digits plus overrange "1" digit.
POLARITY:	Automatic, with "-" indication; "+" indication implied.
OUT-OF-RANGE:	All digits blank, except "1" digit lit.
DECIMAL POINT:	Jumper selectable.
12. POWER REQUIREMENTS:	
Model 2869:	120 or 240VAC $\pm 10\%$ , 50 Hz to 400 Hz, 5VA.
Model 2870:	5VDC, $\pm 5\%$ at 200mA.
13. TEMPERATURE RANGE:	
OPERATING:	0°C to +55°C.
STORAGE:	-40°C to +60°C.
14. RELATIVE HUMIDITY:	0 to 85%, non-condensing.
15. REFERENCE CONDITIONS:	
TEMPERATURE:	23°C $\pm 2^\circ\text{C}$ .
ATMOSPHERIC PRESSURE:	575 to 800 mmHg.
RELATIVE HUMIDITY:	30 to 60%

16. WARM-UP TIME:	Less than 15 minutes at reference conditions.
-------------------	---

Table 1-3. Items Supplied with the Instrument

QTY.	DESCRIPTION	PART NUMBER
1	Mounting Bracket	10-863122
1	Operator's Manual	6-114122
1	Connector, PC Board	22990
	Viking Industries — Type 2VK 15 D/1-2-34	
	US Components — Type UPCR-DIS-CD	
	Amphenol Corp. — Type 225-21521-101-04	

Table 1-4. Optional Mounting Hardware

QTY.	DESCRIPTION	PART NUMBER
1	Panel Adapter, DIN, IEC	22992
1	Panel Adapter, Domestic Type	22993
1	Mounting Bracket, Rear (DIN, IEC)	22991

### 1.3 Theory of Operation

The basic block diagram of these Instruments is shown in Figure 1-1. The analog-to-digital conversion is accomplished by the Dual-Slope Integration technique. In Models 2867 and 2868, all A/D conversion circuitry is contained in an LSI integrated circuit. In Models 2869 and 2870, the input signal is first converted from an AC source into a DC source equivalent before the A/D conversion of the LSI integrated circuit. These Instruments convert an analog DC voltage or AC voltage at the input terminals into a corresponding digital value and polarity which are displayed in numeric form on the 7-segment light-emitting diode (LED) display. The particular current or voltage range is obtained by connecting the appropriate attenuator network to the input.

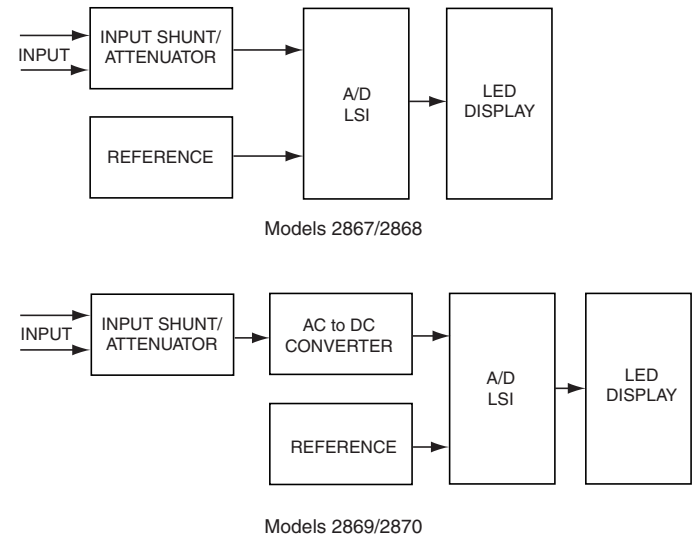

Figure 1-1. Block Diagram

## 2. INSTALLATION



These instruments are designed for maximum safety to the operator when mounted in a panel according to instructions contained in paragraph 2.2. They are not to be used unmounted or for exploratory measurements in unknown circuits.

### 2.1 Safety Precautions

These Instruments do not themselves present a shock hazard, but if connected to auxiliary line operated equipment, the auxiliary circuits must be properly grounded for safety and to prevent improper readings. When connecting Models 2867 or 2869 to a power line circuit, make certain that the ground terminal of the PC board is connected to earth ground as shown in Table 2-1. On Models 2867 through 2870, do not attempt to float the input terminals at more than 250VDC, with respect to power line (earth) ground. Doing so may damage the Instrument. Before removing the power connector from the Instruments, make certain that the circuit power sources are de-energized and any capacitors are discharged.

### 2.2 Panel Mounting Instructions

These Instruments can be mounted on panels ranging from 1/16 to 1/4 inches in thickness without any modification. To mount the Instrument, proceed as follows:

1. Insert the Instrument through the front panel cut-out.
2. Insert a side-mounting bracket (10-863122) on each side of the Instrument. Use the two holes near the bezel as shown in Figure 2-1.
3. Slide the brackets toward the rear of the slots until they lock in place.
4. Turn the screws in each bracket until they firmly contact the panel surface.



Do not tighten the screws. Wait until both screws are snug against the panel surface, then tighten them. Do not over-tighten.

5. Refer to Table 1-1, or Table 1-2 for power requirements. Check that the power source connector is connected to the correct terminals of the PC board connector. Also, be sure that the power source matches the label on the Instrument case. (Refer to paragraph 2.3 for connector wiring and grounding instructions.)

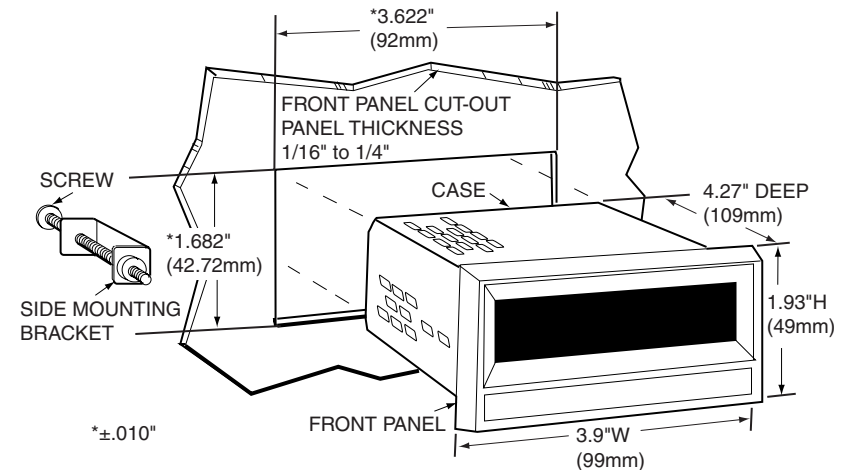

Figure 2-1. Panel Mounting and Cutout Dimensions

### 2.3 Power Source Requirements and Connections



Do not attempt to connect the Instruments to a power source until instructed to do so. Check that the power designation on top of the case agrees with the power source to be used.



When connecting multiple instruments to a common 5V power source, DO NOT exceed the Rated Circuit-to-Ground Voltage (Models 2868/2870 only). Refer to Table 1-1, 1-2.

The 2867/2869 is wired at the factory for 120 volts AC operation (Table 2.1). For 240 volt operation, consult the nearest Authorized Service Center. For proper operation, be sure that the power line ground connection of the 2867/2869 is securely connected to a good earth (power line) ground. Preferably, use a standard 3-wire line cord, and a 3-wire grounded outlet that conforms to the latest electrical code. All power connections are made to the PC board connector. The power requirement of the 2867/2869 is approximately 5VA. The 2868/2870 is wired for 5VDC operation, requiring approximately 200mA.

**2867/2869 Power Connection:** Check that the voltage rating on the label agrees with the source voltage to be used. Do not apply line power until all signal connections are complete. 2867/2869 power connections are in accordance with Table 2-1. 2868/2870 power connections (5VDC) are in accordance with Table 2-1. Observe polarity when making these connections.

Table 2-1.

Pin No.	Models 2867/2869 Circuit	Models 2868/2870 Circuit	Pin No.	Models 2867/2869 Circuit	Models 2868-2870 Circuit
1	3rd-wire GND	NC	A	3rd-wire GND	NC
2	NC	NC	B	NC	NC
3	NC	NC	C	*120VAC, Neutral	NC
4	NC	+5VDC	D	NC	NC
5	NC	NC	E	*120VAC, High	NC
6	NC	NC	F	NC	NC
7	NC	NC	H	(DP COM)	(DP COM)
8	NC	NC	J	Digital Common	Digital Com 5VDC return
9	NC	NC	K	(DP 3)	(DP 3)
10	(-REF/HOLD)	(-REF/HOLD)	L	(DP 2)	(DP 2)
11	(+REF)	(+REF)	M	(DP 1)	(DP 1)
12	NC	NC	N	NC	NC
13	NC	NC	P	-Input Common	-Input Common
14	NC	NC	R	NC	NC
15	NC	NC	S	+Input	+Input

( ) Denotes options. NOTE: Only one option per Instrument.

NC Denotes "no connection."

\* Optional connections for 240VAC operation.

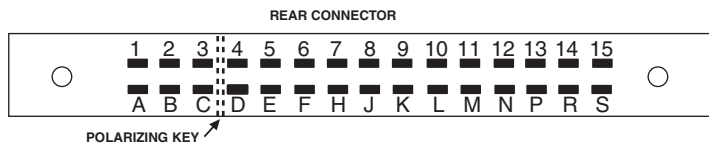

Figure 2-2. Rear Connector Pin Identification



The following servicing instructions are for use by qualified personnel only. To avoid electrical shock, do not perform any servicing other than that contained in the operating instructions unless you are qualified to do so.

### 3. SERVICING INSTRUCTIONS

#### 3.1 Case and Front Cover Removal



Remove all power and connections to the Instrument before removing the case or replacing the fuse.

The case and front cover can be removed for maintenance purposes as follows:

1. Disconnect the Instrument from the AC power source (2867/2869) or turn power OFF.
2. Remove the two screws that attach the PC connector to the Instrument (when used) and remove the PC board connector from the rear of the Instrument.
3. Remove the two screws that attach the front cover to the case and pull the PC board assembly forward out of the case.

#### 3.2 Line Fuse Replacement (2867/2869 only)

The line fuse is located next to the power transformer.

1. Remove the case and front cover as described in paragraph 3.1.
2. Carefully lift the defective fuse from the holder and replace with a 1/8A, 8AG, normal-blow fuse.
3. Replace the case and front cover.

AVAILABLE UPON REQUEST

Schematic Diagram

Parts Listing

**NOTES**

**NOTES**

**SIMPSON ELECTRIC COMPANY** 520 Simpson Avenue  
Lac du Flambeau, WI 54538-0099 (715) 588-3947 FAX (715) 588-1248  
Printed in U.S.A. Part No. 06-114122 Edition 5, 01/07  
Visit us on the web at: [www.simpsonelectric.com](http://www.simpsonelectric.com)