

Simpson[®]

2865 and 2866
3-½ Digit Panel Instruments
INSTRUCTION MANUAL



SIMPSON ELECTRIC COMPANY

520 Simpson Avenue, Lac du Flambeau, WI 54538-0099

(715) 588-3311 FAX (715) 588-3326

Printed in U.S.A. Part No. 06-114937 Edition 6, 01/11

Visit us on the web at: www.simpsonelectric.com

About this Manual

To the best of our knowledge and at the time written, the information contained in this document is technically correct and the procedures accurate and adequate to operate this instrument in compliance with its original advertised specifications.

Notes and Safety Information

This Operator's Manual contains warning headings which alert the user to check for hazardous conditions. These appear throughout this manual where applicable and are defined below. To ensure the safety of operating performance of this instrument, these instructions must be adhered to.



Warning, refer to accompanying documents.



Caution, risk of electric shock.

Technical Assistance

SIMPSON ELECTRIC COMPANY offers assistance Monday through Friday 8:00 am to 4:30 pm Central Time. To receive assistance contact Technical Support or Customer Service at (715) 588-3311. Internet: <http://www.simpsonelectric.com>

Warranty and Returns

SIMPSON ELECTRIC COMPANY warrants each instrument and other articles manufactured by it to be free from defects in material and workmanship under normal use and service, its obligation under this warranty being limited to making good at its factory or other article of equipment which shall within one (1) year after delivery of such instrument or other article of equipment to the original purchaser be returned intact to it, or to one of its authorized service centers, with transportation charges prepaid, and which its examination shall disclose to its satisfaction to have been thus defective; this warranty being expressly in lieu of all other warranties expressed or implied and of all other obligations or liabilities on its part, and SIMPSON ELECTRIC COMPANY neither assumes nor authorizes any other persons to assume for it any other liability in connection with the sales of its products.

This warranty shall not apply to any instrument or other article of equipment which shall have been repaired or altered outside the SIMPSON ELECTRIC COMPANY factory or authorized service centers, nor which has been subject to misuse, negligence or accident, incorrect wiring by others, or installation or use not in accord with instructions furnished by the manufacturer.

This manual represents your meter as manufactured at the time of publication. It assumes standard software. Special versions of software may be fitted, in which case you will be provided with additional details.

The apparatus has been designed and tested in accordance with EN 61010-1, "Safety Requirements for Electrical Equipment for Measurement, Control and Laboratory Use." This operating guide contains information and warnings that must be followed by the user to ensure safe operation and to maintain the apparatus in a safe condition.

We reserve the right to make changes and improvements to the product without obligation to incorporate these changes and improvements into units previously shipped.

Table 2. Pin Connector Circuit Identification

| Pin | Circuit Description | Pin | Circuit Description |
|-----|------------------------------|-----|-------------------------------------|
| 1,A | 3rd wire GND-2865 NC-2866 | B | NC |
| 2,3 | NC | C | *120 AC Neutral-2865 NC-2866 |
| 4 | NC-2865 +5 VDC-2866 | D | NC |
| 5 | NC | E | *120 AC High-2865 NC-2866 |
| 6 | NC | F | NC |
| 7 | NC | H | (DP-COM) |
| 8 | NC | J | Digital Common 5 VDC return-2866 |
| 9 | NC | K | (D.P.3) |
| 10 | (-REF/HOLD) | L | (D.P.2) |
| 11 | (+REF) | M | (D.P.1) |
| 12 | NC | N | NC |
| 13 | NC | P | Input Common (-) |
| 14 | NC | R | NC |
| 15 | NC | S | Input (+) |

() Denoted Options. NOTE: Only one option per Instrument.

NC Denotes "no connection"

*Optional connections for 240 VAC operation.

Table 3. Items Supplied with the Instrument

| Quantity | Description | Part Number |
|----------|---|-------------|
| 1 | Mounting Bracket | 10-863122 |
| 1 | Operator's Manual | 6-114937 |
| 1 | Connector, PC Board | 22990 |
| | Viking Industries — Type 2 KV 15 D/1-2-34 | |
| | US Components — Type UPCR-DIS-CD | |
| | Amphenol Corp. — Type 225-21521-101-04 | |

3. SERVICING INSTRUCTIONS



These servicing instructions are for use by qualified personnel only. To avoid electrical shock, do not perform any servicing other than that contained in the operating instructions unless you are qualified to do so.

3.1 Case and Front Cover Removal



Remove all power and connections to the Instrument before removing the case or replacing the fuse.

The case and front cover can be removed for maintenance purposes as follows:

1. Disconnect the Instrument from the AC power source (2865) or turn power OFF.
2. Remove the two screws that attach the front cover to the Instrument (when used) and remove the PC board connector from the rear of the Instrument.
3. Remove the two screws that attach the front cover to the case and pull the PC board assembly forward out of the case.

3.2 Line Fuse Replacement (2865 only)

1. Remove the case and front cover as described in paragraph 3.1.
2. Carefully lift the defective fuse from the holder and replace with a type 1/8A, 8AG, normal-blow fuse. (The line fuse is located next to the power transformer.)
3. Replace the case and front cover.

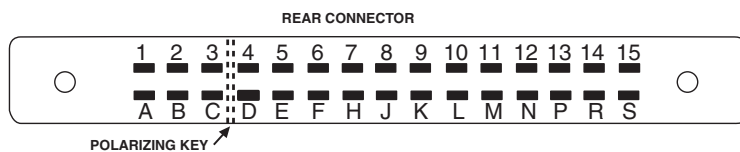

Figure 5. Rear Connector

SHOCK HAZARD: As defined in American National Standard, C39.5, *Safety Requirements for Electrical & Electronic Measuring & Controlling Instrumentation*, a shock hazard shall be considered to exist at any part involving a potential in excess of 30 volts RMS (sine wave) or 42.4 volts DC or peak and where a leakage current from that part to ground exceeds 0.5 milliampere, when measured with an appropriate measuring instrument defined in Section 11.6.1 of ANSI C39.5.

NOTE: The proper measuring instrument for the measurement of leakage current consists essentially of a network of a 1500 ohm non-inductive resistor shunted by a 0.15 microfarad capacitor connected between the terminals of the measuring instrument. The leakage current is that portion of the current that flows through the resistor. The Simpson Model 229-Series 2 AC Leakage Current Tester meets the ANSI C39.5 requirements for the measurement of AC leakage current and can be used for this purpose. To measure DC Leakage current, connect a 1500 ohm non-inductive resistor in series with a Simpson 0-500 DC .microammeter and use this as the measuring instrument.

Contents

| | |
|---|----|
| 1. INTRODUCTION | 5 |
| 1.1 General | 5 |
| 1.2 Safety Precautions | 5 |
| 1.3 Theory of Operation | 7 |
| 2. INSTALLATION | 8 |
| 2.1 Panel Mounting Instructions | 8 |
| 2.2 Power Source Requirements | 8 |
| 2.3 Connections | 8 |
| 3. SERVICING INSTRUCTIONS | 9 |
| 3.1 Case and Front Cover Removal | 10 |
| 3.2 Line Fuse Replacement (2865 only) | 10 |

Model 2865 is securely connected to a good earth (power line) ground. Use a standard 3-wire line cord, and a 3-wire grounded outlet that conforms to the latest electrical code. All power connections are made to the PC board connector. The power requirement of the 2865 is approximately 5 VA. The model 2866 is wired for 5 VDC operation, requiring approximately 200 mA.

2.3 Connections

Refer to Figure 3 for the wiring diagram of the Model 2865 or to Figure 4 for the wiring diagram of the Model 2866.



Do not apply power to the Instrument until all connections are completed.

The signal input connections for the Models 2865 and 2866 are identical. Use either a twisted pair of leads, or 2-wire shielded cable for low level, high output impedance circuits.

Once you've completed wiring the connector, orient the connector polarizing key so that it mates with the slot on the PC board and insert the PC connector onto the PC board. Two No. 4-40 x 5/8" screws are required to permanently attach the PC connector to the Instrument.

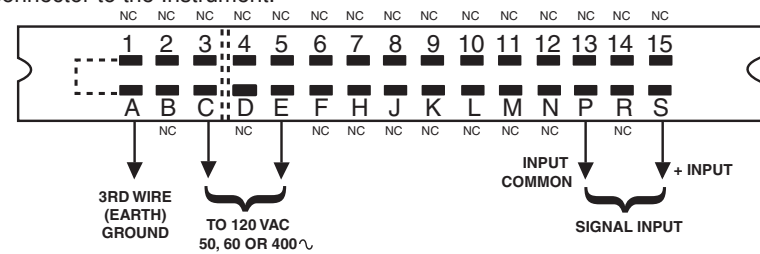

Figure 3. Model 2865, Connector Wiring

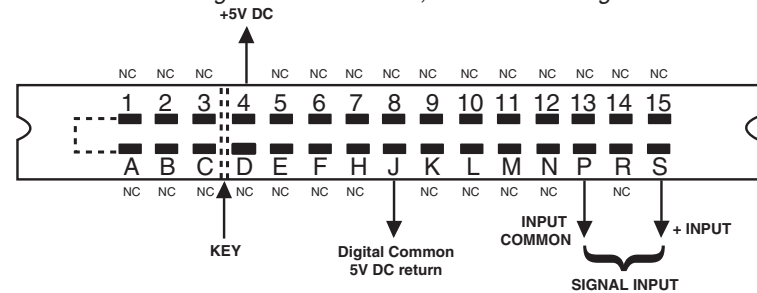

Figure 4. Model 2866, Connector Wiring

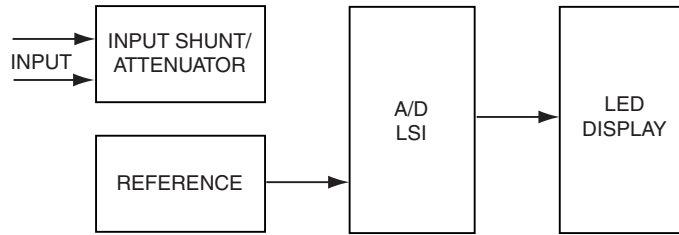

Figure 1. 2865 and 2866 Block Diagram

2. INSTALLATION

2.1 Panel Mounting Instructions

These Instruments can be mounted on panels ranging from 1/16 to 1/4 inches in thickness without any modification. To mount the Instrument, proceed as follows:

1. Insert the Instrument through the front panel cutout.
2. Insert a side mounting bracket (10-863122) on each side of the Instrument. Use the two holes near the bezel shown in Figure 2.
3. Slide the brackets toward the rear of the slots until they lock in place.
4. Turn the screws in each bracket until they firmly contact the panel surface. Do not over-tighten.

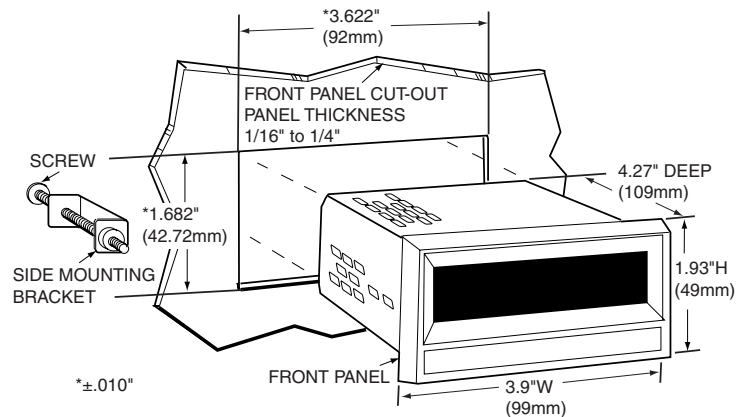

Figure 2. Panel Mounting and Cut-Out Dimensions

2.2 Power Source Requirements



Check that the power designation on top of the case agrees with the power source to be used.

The Model 2865 is wired at the factory for 120 volts AC operation (see Table 1). For 240 volt operation, be sure that the power line ground connection of the

1. INTRODUCTION

1.1 General

The Simpson 2865 and 2866 (hereafter referred to as the 2865 or 2866 or the Instruments) are 3½-digit, panel-mounted instruments that provide visual indication for either DC voltage or DC current measurement. Both Instruments feature 0.1 percent accuracy using solid-state integrated circuit electronics.

The 2865 can be used as a self-contained, panel-mounted unit, operating from either a 120 or 240 volt AC, 50 to 400 Hz power source. The 2866 is designed to operate from a 5 VDC power source. Both Instruments feature solid-state, light-emitting diode (LED) displays, automatic polarity selection and indication, automatic zeroing, excellent temperature characteristics, high input resistance (for DC voltage models), fast response time and automatic out-of-range indication. These Instruments, which provide high reliability and compact design, use a Large-Scale-Integration (LSI) module for the analog-to-digital circuitry.

Both Instruments are especially suited for system-oriented application. The versatility of AC line or DC operation and 200 mV full range sensitivity allow each Instrument to be used as a direct replacement for an analog type instrument. This feature makes it convenient to convert existing instruments or systems from analog to digital display and at the same time improve the performance of a system.

NOTE: This Operator's Manual contains information essential to the operation of this Instrument. Keep in a convenient place and use for reference as required.



These Instruments are designed for maximum safety to the operator when mounted in a panel according to instructions contained in paragraph 2.1. They are not to be used unmounted or for exploratory measurements in unknown circuits.

1.2 Safety Precautions

These Instruments do not themselves present a shock hazard, but if connected to auxiliary line-operated equipment, the auxiliary circuits must be properly grounded for safety and to prevent improper readings.

When connecting the 2865 to a power line circuit, make certain that the ground terminal of the PC board is connected to earth ground.

Do not attempt to float the input terminals at more than 250V DC with respect to power line (earth) ground. Doing so may damage the Instrument.

Before removing the power connector from the Instruments, make certain that the circuit power sources are de-energized and any capacitors are discharged.

Table 1. Technical Data

1. Full Scale Ranges:

DC Voltage

| Range | Maximum Indication | Input Resistance | Catalog Numbers | |
|--------|--------------------|------------------|-----------------|-------|
| | | | 2865 | 2866 |
| 200 mV | ±199.9 mV | 100 MΩ | 24500 | 24600 |
| 2 V | ±1.999 V | 100 MΩ | 24501 | 24601 |
| 20 V | ±19.99 V | 10 MΩ | 24502 | 24602 |
| 200 V | ±199.9 V | 10 MΩ | 24503 | 24603 |

Overvoltage Protected to: 250 V, all ranges.

DC Current

| Range | Maximum Indication | Maximum Input Resistance | Catalog Numbers | |
|--------|--------------------|--------------------------|-----------------|-------|
| | | | 2865 | 2866 |
| 20 μA | ±19.99 μA | 20 mA | 24504 | 24604 |
| 200 μA | ±199.9 μA | 20 mA | 24505 | 24605 |
| 2 mA | ±1.999 mA | 20 mA | 24506 | 24606 |
| 20 mA | ±19.99 mA | 100 mA | 24507 | 24607 |
| 200 mA | ±199.9 mA | 1A | 24508 | 24608 |

Voltage Drop: 200 mA, all ranges.

- 2. Accuracy:** ±(0.1% of input + 1 count) at reference conditions
- 3. Temperature Coefficient:** ±(0.01% of input +0.05 count) per °C from 0° to +55°C
- 4. Sensitivity:** 100 μV for 200 mV unit
10 nA for 20 μA unit
- 5. Resolution:** One part in 2000
- 6. Input Bias Current:** 10 pA maximum at reference conditions
- 7. Full Range Step Response:** 1 second (to rated accuracy)
- 8. Norm. Mode Rejection:** 50 dB minimum at 60 Hz
- 9. Com. Mode Rejection:** 90 dB minimum (2865 only) (with 1 kV unbalance at 60 Hz)

10. Rated Circuit-To-Ground Voltage*:

(Maximum Common Mode Voltage)

- 2865: 250 VDC between either input terminal and power line ground
- 2866: -4.0 to +4.5 VDC between the common (-) input terminal and the power source common (5 VDC return)

*The maximum voltage, with respect to ground, which may safely and continuously be applied to the circuit of an instrument.

11. Conversion:

- Technique: Up-Down Integration
- Rate: 3 samples per second, nominal

12. Display:

- Type: 7-segment, light-emitting diodes with 0.56" high numerals
- Number of Digits: 3 full digits, plus overrange "1" digit
- Polarity: Automatic, with "-" indication; "+" indication implied
- Out-of-Range: All digits blank, except "1" digit
- Decimal Point: Jumper selectable

13. Power Requirements:

- 2865: 120 or 240 VAC ±10%, 50 to 400 Hz, 5 VA
- 2866: 5 VDC, ±5% at 200 mA

14. Temperature Range:

- Operating: 0°C to +55°C at 0 to 85% relative humidity, non-condensing
- Storage: -40°C to +60°C

15. Reference Conditions:

- Temperature: 23°C, ±2°C
- Atmospheric Pressure: 575 to 800 mmHg

16. Warm-Up Time:

Less than 15 minutes at reference conditions.

1.3 Theory of Operation

The basic block diagram of both Instruments is shown in Figure 1. The analog-to-digital conversion is accomplished by the Up-Down Integration technique. All A/D conversion circuitry is contained in an LSI integrated circuit. These Instruments convert an analog DC voltage at the input terminals into a corresponding digital value and polarity which are displayed in numeric form on the 7-segment light-emitting diode (LED) display. The particular current or voltage range is obtained by connecting the appropriate attenuator network to the input.