

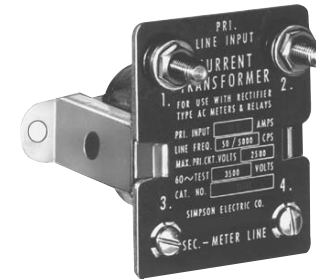

## Current Transformer Model 186 INSTRUCTION MANUAL



**SIMPSON ELECTRIC COMPANY** 520 Simpson Avenue  
Lac du Flambeau, WI 54538-0099 (715) 588-3311 FAX (715) 588-3326  
Printed in U.S.A. Part No. 06-112122 Edition 6, 05/07  
Visit us on the web at: [www.simpsonelectric.com](http://www.simpsonelectric.com)

**About this Manual**

To the best of our knowledge and at the time written, the information contained in this document is technically correct and the procedures accurate and adequate to operate this instrument in compliance with its original advertised specifications.

**Notes and Safety Information**

This Operator's Manual contains warning symbols which alert the user to check for hazardous conditions. These appear throughout this manual where applicable, and are defined below. To ensure the safety of operating performance of this instrument, these instructions must be adhered to.

 Warning, refer to accompanying documents.

 Caution, risk of electric shock.



This instrument is designed to prevent accidental shock to the operator when properly used. However, no engineering design can render safe an instrument which is used carelessly. Therefore, this manual must be read carefully and completely before making any measurements. Failure to follow directions can result in a serious or fatal accident.

**Technical Assistance**

SIMPSON ELECTRIC COMPANY offers assistance Monday through Friday 8:00 am to 4:30 pm Central Time. To receive assistance contact Technical Support or Customer Service at (715) 588-3311.

Internet: <http://www.simpsonelectric.com>

**Warranty and Returns**

SIMPSON ELECTRIC COMPANY warrants each instrument and other articles manufactured by it to be free from defects in material and workmanship under normal use and service, its obligation under this warranty being limited to making good at its factory or other article of equipment which shall within one (1) year after delivery of such instrument or other article of equipment to the original purchaser be returned intact to it, or to one of its authorized service centers, with transportation charges prepaid, and which its examination shall disclose to its satisfaction to have been thus defective; this warranty being expressly in lieu of all other warranties expressed or implied and of all other obligations or liabilities on its part, and SIMPSON ELECTRIC COMPANY neither assumes nor authorizes any other persons to assume for it any other liability in connection with the sales of its products.

This warranty shall not apply to any instrument or other article of equipment which shall have been repaired or altered outside the SIMPSON ELECTRIC COMPANY factory or authorized service centers, nor which has been subject to misuse, negligence or accident, incorrect wiring by others, or installation or use not in accord with instructions furnished by the manufacturer.

**NOTES:**

This Instrument is designed to prevent accidental shock to the operator when properly used. However, no engineering design can render safe an instrument which is used carelessly. Therefore, this manual must be read carefully and completely before making any measurements. Failure to follow directions can result in serious or fatal accident.

# Contents

1. GENERAL .....	5
1.1 Current Transformers .....	6
2. INSTALLATION .....	7
3. MEASUREMENT OF CURRENT OVER 50 AMPS .....	8
3.1 Current Transformers For Use With AC Ammeters .....	8

All Simpson “donut” type transformers have 5 amp secondaries and may be connected directly to a 5 amp 186 (Catalog No. 01312) Current Transformer.

An iron-vane type 0-5 amp meter may be connected in series with the “donut” transformer to monitor the current, but the connector’s leads must be kept very short. A 0-5 amp iron-vane type meter has an impedance of about 0.008  $\Omega$  and it can readily be seen that wire resistance can seriously affect the accuracy of the reading. Only the output of the Transformer may be monitored remotely.

**NOTE:** The “donut” transformer’s limited frequency response of 50 - 400 Hz limits the frequency range of this application for the Transformer to 50 - 400 Hz.

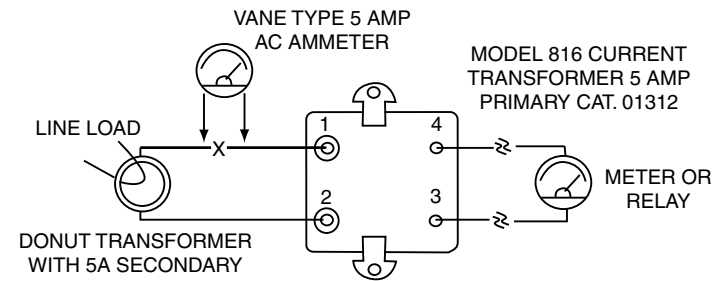

Figure 3-2. Typical wiring arrangement over 50 amps.

### 3. MEASUREMENT OF CURRENT OVER 50 AMPS

The Transformer permits remote meter location or meter relay operation from circuits up to 1000A when used in conjunction with a one-turn primary “donut” transformer. The “donut” secondary current must match the current rating of the Transformer.

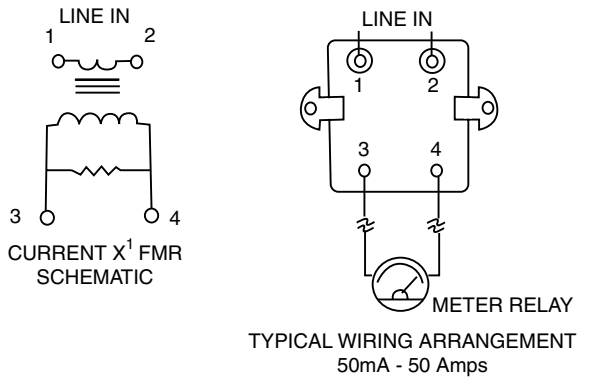

Figure 3-1

#### 3.1 Current Transformers For Use With AC Ammeters

Insert one-turn primary-type for use with switchboard and panel ammeters where external transformers are required. Rate at 2 VA. Have 2' leads.

Table 3.1. Transformers for use with AC Ammeters

Primary	Amperes Secondary	Catalog No.
50	5	01293
75	5	01306
100	5	01297
150	5	01298
200	5	01299
250	5	01313
300	5	01300
400	5	01305
500	5	01301
600	5	02303
750	5	02459
1000	5	02304

### 1. GENERAL

The Simpson Model 186 Current Transformer (hereafter referred to as the Transformer) is designed to enable the measurement of AC current to be (remotely) taken from the circuit to be measured. Connected in series with a circuit, the transformer output is designed to produce 0-10 volts over the rated current range of the transformer primary and a full scale indication on a 0-10 volt, rectifier type AC voltmeter (min. 2000 Ω/V) or a meter relay.

Used with a meter relay, the Transformer can provide a control function based on the current flowing through the transformer. The transformer secondary is shunted by a loading resistor (approx. 600 Ω) to protect the transformer in the event of loss of the load circuit and to calibrate the transformer for its primary current rating.

The meter impedance (20,000 Ω min.) is a bridging circuit across the low impedance secondary which minimizes the reading error introduced by the secondary-to-meter connecting leads at a distance of up to 500 feet or more, depending on the wire size (resistance).

A 500 foot run of two (#20 AWG) conductors, for example, would introduce approximately 10 Ω in series with the 20,000 Ω meter and cause a negligible (approx. 0.1%) error of the reading.

For current ranges above 50 amps, the Transformer may be used in conjunction with a one-turn primary “donut” transformer.

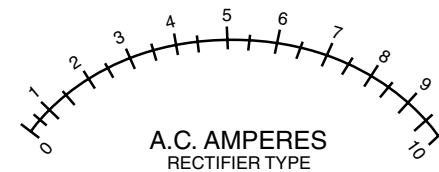

Figure 1-1. Scale.

Typical scale distribution. AC Amperes used with Model 186 Current Transformers.



The Transformer should not be used where sustained overloads are possible. Surge Ratings are found in Table 1-2, Specifications.

## 1.1 Current Transformers

Table 1-1. Current Transformers

Range	V.A. Burden	Catalog No.
500 MA	.53	01304
100 MA	.50	01295
50 A	.54	01321
40 A	.42	01319
30 A	.37	01318
25 A	.53	01317
20 A	.48	01316
15 A	.37	01315
10 A	.50	01314
5 A	.40	01312

Any 0-10 VAC rectifier type voltmeter with a sensitivity of at least 2000 $\Omega$  per volt may be scale calibrated to the current range of the Transformer and obtained from any Authorized Service Center.

Table 1-2. Specifications.

### SPECIFICATIONS:

<b>Ranges Available:</b>	Refer to Table 1-1
<b>V.A. Burden:</b>	Refer to Table 1-1
<b>Frequency Range:</b>	50-5000 Hz
<b>Accuracy:</b>	$\pm 2\%$ + accuracy of meter ( $\pm 4\%$ typical) for sinusoidal voltages at 25°C
<b>Max. Rated Circuit-To-Ground Voltage*:</b>	750 VAC
<b>Secondary Voltage:</b>	0-10V over the current range of the transformer into the appropriate voltmeter.

\*The highest working voltage, with respect to earth ground, for which the current winding is insulated.

### Max. Surge Current:

CURRENT RANGE	MAX. SURGE
.05 to 10a	10X Range
15 to 25A	125A
30 to 50A	50A

### Temperature Range:

Operational:	-30°C (-22°F) to 60°C (140°F)
Storage:	-60°C (-76°F) to 85°C (185°F)

### Construction:

Channel flange-mounted open type, varnish-vacuum impregnated windings on nylon bobbin. Phenolic laminate terminal board permanently attached to the channel. Studs, (1/4-28) for current winding connections, binding (-32) head screws for output voltage connections.

## 2. INSTALLATION

1. The Transformer must be installed and connected by a qualified electrician in accordance with provisions of the National Electrical Code.
2. Mount the Transformer using 8-32 screws as near as practical to the circuit to be measured, keeping it away from heat producing devices.
3. The choice of conductors into which the current coil is to be connected, depends on the information desired. Connected into the ungrounded conductor, the meter will indicate the sum of the load current, plus any ground fault current.
4. Connected into a neutral conductor, the meter will indicate the load current, but not any ground fault current. Connection into a neutral conductor has the advantage of eliminating any dielectric stress upon the Transformer's insulation.

Figure 2.1

5. Conductors to the current-winding must be a wire size and voltage rating

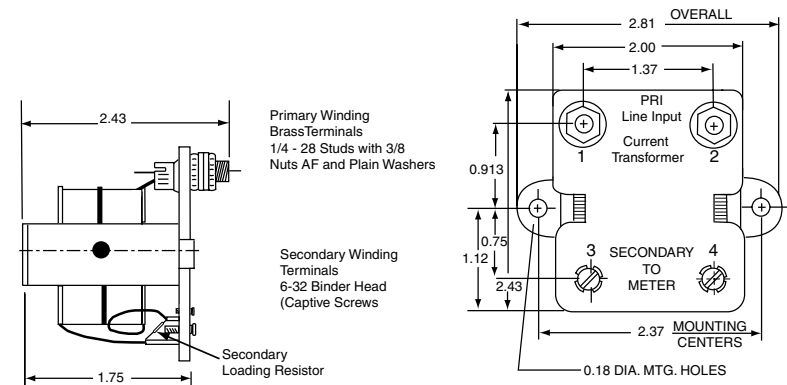

6. Connectors between the Transformer secondary and the meter/relay should be in accordance with requirements for National Electrical Code, class 2 circuits. Wire size is not critical for short distances, but should be as large as possible for distances of 500 feet or more. (See paragraphs 3 and 4, under General Information, page 5.)