



## Hawk™ II H235 Series Advanced DPM

- Easily Programmed from the Front Panel
- User-Friendly Software Functions Include:
  - Password
  - Display Scaling
  - Decimal Point Selection
  - Set Point Programming
  - Peak-Valley Values
  - Time Delay & Hysteresis
- Screw Terminal Connector for Easy Installation
- 1/8 DIN, Shallow Depth Case, 3.24" (82mm) for Restricted Space Behind Panel
- Five AC Voltage Ranges: 200mV, 2V, 20V, 200V, 600V
- Optional 5 Amp Relay Outputs, Excitation Outputs and Analog Outputs



Simpson's Hawk II microprocessor-based advanced digital panel meters are ideal for measuring and controlling a wide variety of process variables. The display can be easily scaled from the front panel to virtually any engineering units. Excitation outputs are available for external transmitters and transducers.

Two optional 5 amp relays include programming features for hysteresis, time delay and relay operation. Optional analog outputs are also available. Other programmable software features include programmable decimal point and a pass-

word lockout feature. Depending on the password value chosen, the customer may lock out all changes or only those relating to setup -- leaving the set point values accessible to the operator.

The Hawk II series advanced digital panel meters are compactly designed for applications requiring minimal rear panel depth, and feature a standard 1/8 DIN case with a depth behind the panel of only 3.24" (82mm). Screw terminals are standard for easy installation.

### Installation and Panel Cutout

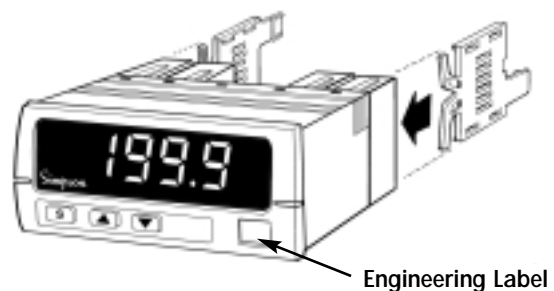
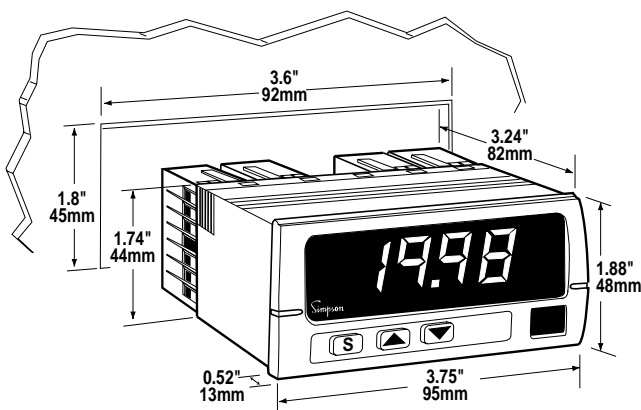

#### Mounting Requirements

The Hawk II series 1/8 DIN advanced digital panel meters require a panel cutout of 1.77" (45mm) high by 3.62" (92mm) wide. To install the Hawk II into a panel cutout, remove the clips from the sides of the meter. Slide the meter through your panel cutout, then slide the mounting clips back on the meter. Press evenly to ensure a proper fit.

#### Engineering Label Placement

If replacement of the engineering unit label is required, place the tip of a ball-point pen into the small hole at the base of the engineering label in the bezel. Slide the label up until it pops out. Grasp and remove. Slide the new label half the distance in, then use the ball-point pen to slide it down into place.

## Specifications

### DISPLAY

**Type:** 7-segment, red LED

**Height:** 0.56" (14.2mm)

**Decimal Point:** 3-position software programmable from front panel

**Overrange:** Display reads "EE"

**Underrange:** Display reads "-EE"

**Alarm Indicators:** 2 LED indicators for alarm conditions on front panel

### POWER REQUIREMENTS

**AC Voltages:** 24, 48, 120, 220VAC,  $\pm 10\%$

**DC Voltages:** 12-48VDC,  $\pm 15\%$

**Power Consumption:** 6VA

### ACCURACY:

0.3% of reading  $\pm 3$  counts

### APPROVALS:

UL Recognized, CSA and CE certified

### ENVIRONMENTAL

**Operating Temperature:** 0°C to +50°C

**Storage Temperature:** -10°C to +60°C

**Relative Humidity:** <90% non-condensing

**Ambient Temperature:** 23°C

**Temperature Coefficient (per °C):**

$\pm 100\text{PPM}/^\circ\text{C}$

$\pm 0.05\text{dgt}/^\circ\text{C}$

**Warmup Time:** 10 minutes

### NOISE REJECTION

**NMRR:** 50db, GR = 50V

**CMRR:** 100db, GR = 1K $\Omega$

### ANALOG TO DIGITAL CONVERSION

**Technique:** Special dual slope

**Rate:** Approximately 2 display updates per second, nominal

### MECHANICAL

**Depth:** 3.24" (82mm)

**Bezel:** 3.75" x 1.88" x 0.52"

(95mm x 48mm x 13mm)

**Panel Cutout:** 3.6" x 1.8"

(92mm x 45mm) 1/8 DIN

**Case Material:** ABS/polycarbonate blend

**Weight:** Approximately 10.5oz (297.7g)

### INPUTS: AC Voltage

Input Range	Display Resolution	Input Impedance	Maximum Overload
200mV	0.1mV	100K $\Omega$	50V
2V	1mV	100K $\Omega$	230V
20V	10mV	1M $\Omega$	690V
200V	100mV	1M $\Omega$	690V
600V	1V	1M $\Omega$	690V
			Max. 1 min.

## Wiring Diagram

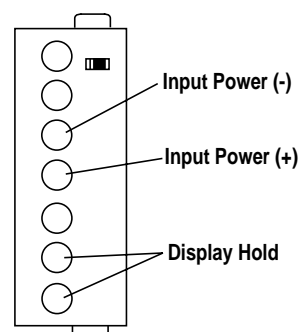
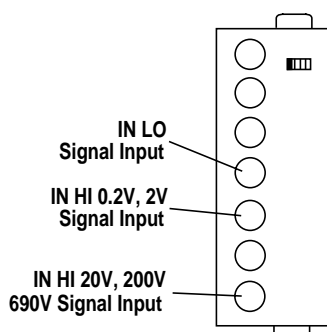

**Input Signal:** Connect the signal to be monitored to the **IN HI** and the **IN LO** terminals. Note that the **IN HI** signal has two terminals that can be used, depending on the amount of voltage being monitored. The upper **IN HI** terminal accepts 0.2 and 2V. The lower **IN HI** terminal accepts 20, 200, and 600V.

**Supply Power:** Connect the appropriate power to the **supply power** terminals.

**Display Hold:** Short the terminals marked **HOLD** to activate. The comparison of the input variable with the alarm set point remains active. To reactivate this display, disconnect the short circuit.

## Programming

The Programming mode allows the user to define the instrument parameters:

- Password for access to programming
- Decimal point position
- Minimum and maximum values of the electrical range
- Display scaling

The normal measurement and control functions are not active during programming mode. The output relays are de-energized. Analog outputs are low.

Termination of programming mode and return to the measurement and control mode is automatic at the end of all the programming steps or after three minutes with no key activation. Display will briefly show "End," then "Run."

### Access to programming

Press and hold the **S** key and then press **▲**. The display should show "PAS." During this phase the instrument asks for the password, which is

a number from 0 to 199. The instrument is delivered with a password of 0. Use the **▲** and **▼** keys to change the displayed value. Press **S** to enter the password and move to the next parameter.

If a number from 0 to 99 is used as the password, the operator cannot change any of the parameters without knowing the password. This is helpful in locking out the front panel from accidental programming. In situations where the operator needs the flexibility to change the set points only, use a password from 100 to 199. This allows the operator to access the set point programming mode, but jumps past the other programming functions. If the correct password is entered, the programming functions are accessed as normal.

### Forgot your password?

If the password is forgotten, it can be reset to 0. The unit must be powered down. Hold down the **S** key and the **▼** key at the same time, and power up the unit. Release the keys when the display shows "PAS" for about two seconds. Press the **▲** key so the display reads "99." Press the **S** key to enter this value, and the reset is done automatically. The mode is terminated, and the system is restarted.

## Programming (Cont'd)

### Programming a new password

To retain the present value for the password, press the **S** key to pass to the next parameter.

To modify the password, press the **▲** and **▼** keys to affect the value. Remember that the value must be a number from 0 to 199. Press **S** to move to the next parameter.

### Decimal Point Selection

The display will show "**dP**" for about two seconds. The display will then show the current position of the decimal point (see the following figure). Change the position with the **▲** and **▼** keys. Press **S** to move to the next parameter.

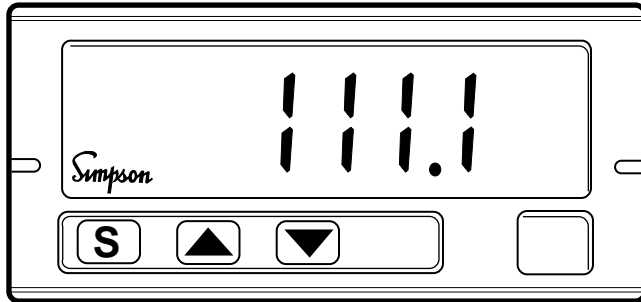

### Programming the electrical input range (HiE and LOE)

This feature allows you to define the electrical input range. It also allows you to define a range different from the standard one.

The display will show "**HiE**," signifying the maximum electrical input range. The value stored in memory is displayed. To retain the present value, press the **S** key. Use the **▲** and **▼** keys to change the displayed value. Press the **S** key when the correct value is displayed.

The Display will show "**LoE**" for about two seconds, signifying the minimum electrical input range. The display will then show the value stored in memory. Use the **▲** and **▼** keys to change the displayed value. Press the **S** key when the correct value is displayed.

The HiE and LOE values are shown in the same engineering units as the input range.

### Display Scaling

This allows you to define the display span (in engineering units) corresponding to the previously defined electrical input range. For example:

Programmed electrical input range: 0.00 to +19.99 (LOE to HiE)

Programmed display span: 0 to 100% (LO to Hi)

**LO** = displayed value corresponding to the minimum of input range (LoE).

**Hi** = displayed value corresponding to the maximum of input range (HiE).

The link between the electrical and the displayed value is completely adjustable/variable, thus it is possible to correlate a minimum electrical value to a maximum display value, and vice versa (scale inversion).

For best resolution, see formula below.

$$\left| \frac{\text{HiE} - \text{LoE}}{\text{Hi} - \text{Lo}} \right| \geq 1$$

The display will show "**Hi**" for about two seconds. Then the display will indicate the Hi value stored in memory.

Use the **▲** and **▼** keys to change the displayed value. The maximum is +1999. Press the **S** key when the correct value is displayed.

The display will show "**Lo**" signifying the minimum of the display span. The display shows the valued stored in memory. To modify the value, use the **▲** and **▼** keys. The value can be as low as -1999 in the meter. Press the "S" key to pass to the next parameter.

The programming sequence will end here and revert to normal operation unless there are relays built into the unit. If so, the meter will display SP1. This information is in the Programming the Relays section.

## Programming the Relays

The Hawk II automatically senses if a relay card is present in the instrument. Programming continues after you have set the HI parameter. When relays are present you must program the following values (in this order):

- Set point values
- Hysteresis
- Time delay
- High or low alarm levels
- Relay status
- Overrange status

The programming for set point value (SP1), hysteresis (HYS), time delay (dEL), high (uP) or low (do) alarm levels, relay status (nE and nd) and overrange status (On/OFF) is performed in the same manner:

1. The display will show "SP1" (or other programming variable), and then display the stored set point value.
2. To retain the present value, press the **S** key to pass to the next parameter.
3. To select a new value, press the **▲** or **▼** key to increase or decrease the displayed value.
4. Press **S** when you have reached your desired value to pass to the next parameter.

**Set Point Values:** The set point is relative to the display span and not to the electrical input range. You can program a password to enable only the set points to be changed. This allows the operator flexibility in using the Hawk II, without the potential for erroneous programming of other parameters. If an incorrect password is entered, the program jumps to the SP1 mode. If the correct password is entered (100-199), the operator can change the parameters.

**Hysteresis:** Hysteresis is the difference between the programmed set point value (value at which the alarm is set ON) and the value at which the alarm is disabled. If a reading is flipping between two points that are above and below the set point, this can cause the relay to "chatter" on and off rapidly. Hysteresis helps eliminate "chatter" in the relays. The value is selected from 1 to 1999.

**Time Delay:** The Time Delay is programmable from 0 to 99 seconds. Time delay is similar to hysteresis, but instead allows the input to exceed the set point for a specific amount of time before triggering the relay. For example, "2" would delay the relay from energizing for two seconds after exceeding the set point. The time delay is reset when the input falls below the set point.

**High and Low Alarm:** You must choose if the relay is to be triggered when the input exceeds (for High Alarm = uP) or falls below (Low Alarm = do) the set point.

**Relay Status:** This parameter determines the state of the relay in the absence of an alarm: normally energized, or normally de-energized.

**Overrange Status:** This allows the user to choose if the relay is on (energized) or off (de-energized) in an overflow/underflow condition.

At this point, if a second relay is also installed in the unit, "SP2" will be displayed, and this procedure repeated for the second relay. After all parameters have been programmed, the programming mode is terminated automatically, and the system restarts. In normal operation, the set points can be displayed by pressing the **▲** key to show SP1 or the **▼** key to show SP2.

## Relays

Optional relays are available with the Hawk II. The relays are 5-amp, 250 VAC, SPDT models. Up to two relays can be installed in the Hawk II. The relays are programmed through the software in the Hawk II to be normally energized or normally de-energized, and are activated (or deactivated) based on the set points. Hysteresis for the relays is easily programmed in the Hawk II to eliminate "chatter" in the relays. The Hawk II has a time delay adjustment of 0 to 99 seconds for the set points.

Relays can be used to "turn on" or "turn off" power to a process that the Hawk II is monitoring. A light can be "turned on" when a set point is exceeded, alerting the operator to a change in condition in the process. Also, the excitation or analog output of the Hawk II can be controlled with the relays by wiring them together, "turning on" or "turning off" the excitation when a set point is reached or exceeded.

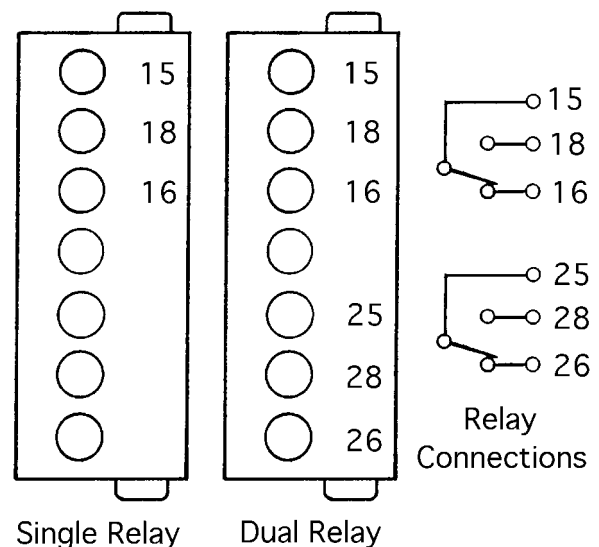

## Excitation Output

Optional 12 or 24VDC excitation power supply is available on the Hawk II. This excitation power can be used to energize many common types of transducers and transmitters. By using the excitation power from the Hawk II, you do not have to set up an external power source for transmitters or transducers.

The source is isolated from the measurement input as well as the input power circuits. The wire is simply connected to the +EXC and the -EXC terminals on the rear of the meter. Maximum current load is 20 mA for 12VDC and 20mA for 24VDC.

**Note:** Excitation power is not available in conjunction with analog output.

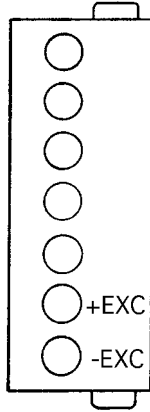

## Peak-Valley

By pressing both the ▲ and the ▼ keys at the same time, the highest and lowest values are displayed. These are referred to as the peak and valley values. The Hawk II displays the peak first, then the valley, then returns to the normal operation. To reset the values in memory. Press all three buttons at the same time to reset the values in memory.



## Analog Output

All analog output signals are linearly proportional to the displayed values.



Isolation voltage of 125 Vrms between analog output and the rest of the Hawk II system limits the use of the system, and is only intended to break ground loops, not as a safety isolation.

### 4-20 DC mA Output signal:

Relationship between the output signal and displayed value:  $I = \frac{16}{Hi-Lo} (RDG-Lo) + 4$

I = Output current (mA)

Hi = Maximum programmed value of the measuring range

Lo = Minimum programmed value of the measuring range

RDG = Displayed value

### 0-20 DC mA Output signal:

Relationship between the output signal and displayed value:  $I = 20(RDG-Lo) / Hi-Lo$

I = Output current (mA)

Hi = Maximum programmed value of the measuring range

Lo = Minimum programmed value of the measuring range

RDG = Displayed value

### 0-10 VDC Output signal

Relationship between output signal and displayed value:  $V = 10(RDG-Lo) / Hi - Lo$

V = Output voltage (V)

Hi = Maximum programmed value of the measuring range

Lo = Minimum programmed value of the measuring range

RDG = Displayed value

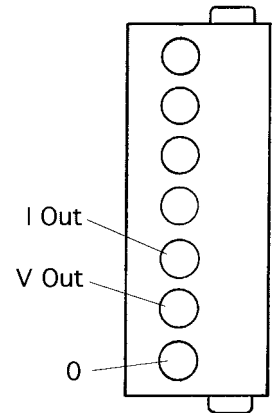

### Relationship between over/underrange situations and Analog outputs:

Input Signal to Hawk II	Display Indication	Output 4-20mA	Output 0-20mA	Output 0-10V
Overrange	EE	20mA	20mA	10V
Underrange	-EE	4mA	0mA	0V

Output Range	Accuracy	Temperature Drift	Max. Load Resistance	Output Resistance	Short Circuit Protection
4-20mA	±1% ±0.1mA	±200PPM/°C	500 Ohm	N/A	Yes
0-20mA	±1% ±0.1mA	±200PPM/°C	500 Ohm	N/A	Yes
0-10V	±1% ±0.05V	±200PPM/°C	N/A	≥1000 Ohm	Yes

**NOTE:** Analog output is not available in conjunction with excitation.

## Application Example

The plant supervisor wants a remote monitor of a current load of an ore grinder, and needs an alarm to be turned on if the load exceeds 25 AC amps. A HAWK II (20VAC) with 1 relay and a Model 186 Transformer (cat. # 01318) can solve the problem.

The transformer is connected in series with the source and load, and the lead wires connected to the HAWK II AC Volt meter remotely located on a mezzanine. The transmitter emits a 0-10 ACV signal.

The HAWK II must have the following parameters programmed: alarm set point values, hysteresis, time delay, alarm levels, and relay status.

The alarm set point should be set at 25, as the set point is relative to the display span, not the electrical input range.

Hysteresis is set at 10. This will help eliminate "chatter" in the relay.

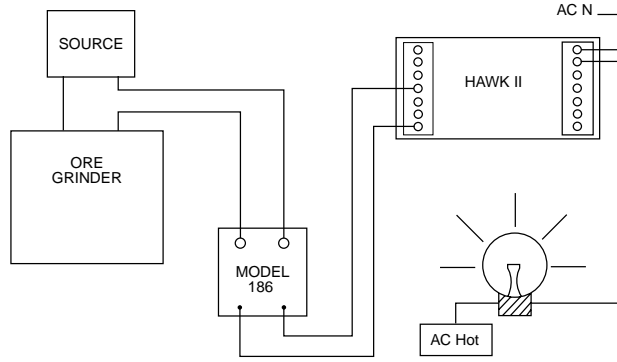

Time delay should be set at 1, which will allow the load to exceed 25 amps for one second before activating the relay.

Set alarm level for "uP" so that the relay is energized when the current exceeds 25 amps.

Relay Status is normally de-energized ("nd").

To scale the display, HiE should be set at 10.0(V), and LOE set at 0.0(V). Hi should be set at 30.0(amps) and Lo set at 0.0(amps).

## Ordering Information

Basic Unit	Power Supply	Function/Range	Output Signal	Number of Relays	Excitation
<b>H235</b>					
3-1/2 Basic Unit					
	1 120VAC 2 220VAC 3 24VAC 4 48VAC 5 12-48VDC*	0310 200mV 0320 2V 0330 20V 0340 200V 0350 600V	0 None 1 4-20mA 2 0-20mA 3 0-10V	0 None 1 One 2 Two	0 None 1 12VDC 2 24VDC
					<b>Note:</b> Excitation not available with output signal.

## Safety Symbols



The WARNING sign denotes a hazard. It calls attention to a procedure, practice, or the like, which, if not correctly performed or adhered to, could result in personal injury.

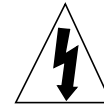

The CAUTION sign denotes a hazard. It calls attention to an operating procedure, practice, or the like, which, if not correctly adhered to, could result in damage to or destruction of part or all the instrument.

## Accessories

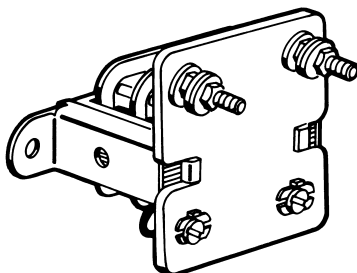

Model 186 Current Transformers easily convert a current signal (up to 50 amps) into a 0-10 AC volt signal and transmit the signal over a long distance. This allows remote monitoring of a process or application.

These units can be coupled with a Donut Current Transformer if a high current rating (up to 1999 amps) is to be monitored at a remote location.

## Ordering Information

Range	VA	Cat. Number
0-1 amp	0.42	01308
0-2 amp	0.54	01309
0-3 amp	0.66	01311
0-5 amp	0.75	01312
0-10 amp	1.45	01314
0-15 amp	1.05	01315
0-20 amp	1.04	01316
0-25 amp	1.50	01317
0-30 amp	1.10	01318
0-40 amp	1.09	01319
0-50 amp	1.90	01321
0-50mA	0.40	01294
0-100mA	0.50	01295
0-200mA	0.37	01296
0-300mA	0.48	01303
0-500mA	0.53	01304
0-750mA	0.37	01307