



Mini-Max M245 Series Digital Panel Meter

- Minimum Depth Indicator - Less Than 2.5" (60mm) of Space Required Behind the Panel
- Stackable Mounting Bracket Included for Easy Installation
- LCD: 4-1/2 Digit, 0.5" (12.7mm) High Display with Optional Negative Image, Bright Red Backlighting
- LED: 4-1/2 Digit, 0.4" (10.2mm) High Display
- Limited Range Display Scaling
- Standard Screw Terminals for Easy Installation
- LCD: Four Voltage Ranges: 200mV, 2V, 20V, 200V, 270V
- LED: Five Voltage Ranges: 200mV, 2V, 20V, 200V, 600V
- 85-250VAC or 9-32VDC Power Supply



LCD



LED

Simpson's Mini-Max Voltage Indicators provide high quality, accuracy and reliability in a compact, 60mm deep case.

LCD (Liquid Crystal Display) Units offer a 4-1/2 digit, 0.5" (12.7mm) LCD display with an optional bright red, negative image, backlight.

LED (Light Emitting Diode) Units offer a 4 1/2 digit, 0.4" (10.2mm) display.

All units feature user-selectable decimal point, auto zero and limited scaling capabilities.

A unique mounting bracket is provided to allow for vertical or horizontal stacking of multiple indicators. All Mini-Max units feature a 3/64 DIN, high-impact plastic case. The LCD units have a clear viewing window and the LED units have a red viewing window.

Installation and Panel Cutout

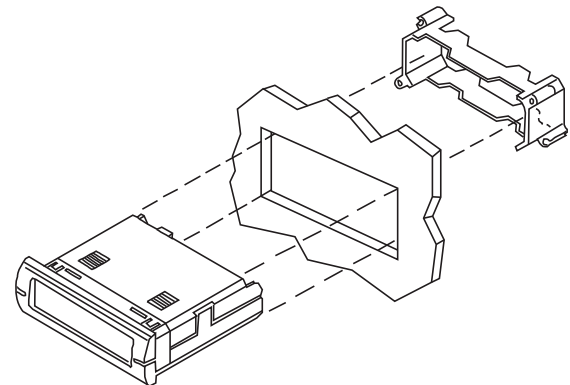
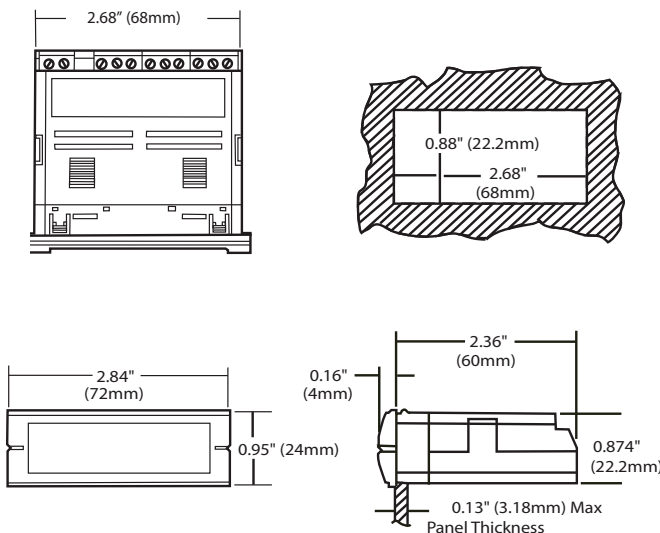

Mounting Requirements

Insert the Mini-Max through the panel, and then slide the mounting bracket onto the Mini-Max. The mounting bracket allows Mini-Max units to be stacked side-to-side or top-to-bottom and to maintain the DIN standard panel arrangements in 24mm by 72mm multiples. Panel cutout instructions for stacking multiple units are provided under "stacking features."

Specifications

DISPLAY

Type: 7-segment LCD or LED
Height: LCD 0.5" (12.7mm)
 LED 0.4" (10.2mm)

Decimal point: 4-position programmable

Overrange indication :
 LCD Most significant digit = "1"
 LED Blinking display

LCD Backlighting: Optional negative image, red backlight

Polarity: Auto with "-" indication, "+" implied

POWER REQUIREMENTS

AC Volt: 85-250VAC @40-440Hz
DC Volt: 9-32VDC

Power Consumption: (Non Fused)

85-250VAC: LCD 4.0VA min (2.4W) max
 LED 3.6VA (2.16W) max

9-32VDC: LCD 3W max
 LED 2W max

Isolation: 250Vrms max

NOISE REJECTION

CMRR: 86dB typical

ACCURACY @ 25°C

LCD $\pm(0.5\%$ of reading + 50 count)
 (50 Hz - 2KHz)

LED $\pm(0.5\%$ of reading + 10 count)
 (50 Hz - 5KHz)

ENVIRONMENTAL

Operating Temperature: 0 to 55°C

Storage Temperature: -10 to 60°C

Relative Humidity: 0 to 85% non condensing @ 40°C

Temperature Coefficient:

(0.2% of reading \pm 0.5 digits/°C)

Warmup time: Less than 20 minutes

ANALOG TO DIGITAL CONVERSION

Technique: Integrating dual slope

Rate: 3 samples/second-typical

MECHANICAL

Bezel: 0.95" x 2.84" (24mm x 72mm)

Depth: 2.36" (60mm)

Panel cutout: 0.88" x 2.68"(22.2mm x 68mm)

Weight: LCD 3.5oz (99.2g)

LED 2.6.oz (74g)

Case Material:

94-0, UL-rated, glass-filled thermoplastic

Range	Resolution	Input	Max Input
	M245	Impedance	Unfused
200mV	10uV	500K	10Vac
2V	100uV	100K	100Vac
20V	1mV	1MEG	200Vac
200V	10mV	1MEG	200Vac
270V	100mV	1MEG	270Vac
600V	100mV	9.9MEG	600Vac

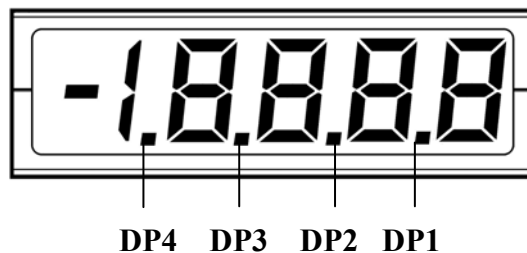

Connections

LCD VERSIONS

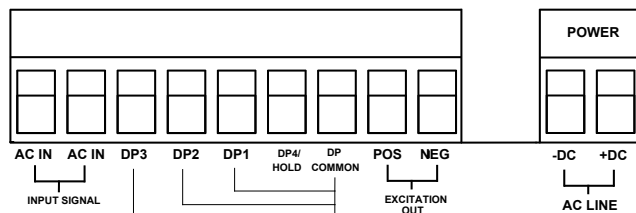

LED VERSIONS

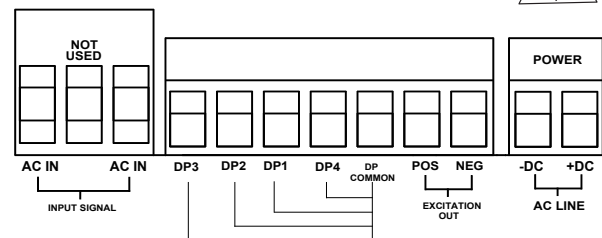

WARNING: These instruments are designed for maximum safety to the operator when mounted in a panel according to instructions. They are not to be used unmounted or for exploratory measurements in unknown circuits.

- Input Signal:** Connect the AC signal to be monitored to the **AC IN** input terminals.
- Input Power:** For AC power, connect the AC POWER LINE to the **AC LINE** inputs. For optional DC power, connect the DC Supply to the DC inputs. Observe polarity.
- Decimal Point:** To select a decimal point, connect the appropriate DP input pin (DP1 - DP4) to the DP COMMON output. Unused DP inputs may remain unconnected (open).
- LCD Hold Option:** Connect the DP COMMON output to the **HOLD** input. If this feature is not required, the HOLD pin may remain unconnected. Hold is optional on LCD versions only, replaces DP4 and is available from our modification center.
- LCD Backlight Option:** Negative image, bright red backlighting is available for the LCD versions only. This illumination allows the unit to be read in low light areas. Backlighting power is supplied by the Mini-Max, so no additional external power is required.
- Excitation Option:** Excitation is available at the **EXCITATION OUT** Positive (**POS**) and Negative (**NEG**) terminals for powering external transmitters or transducers. This source is isolated from the measurement input as well as the input power circuits. The voltages available are 12Vdc or 24Vdc with a maximum load current of 25mA. This feature eliminates the need to mount an external DC power source for transducers or sensors used in your application.

LCD Display Scaling

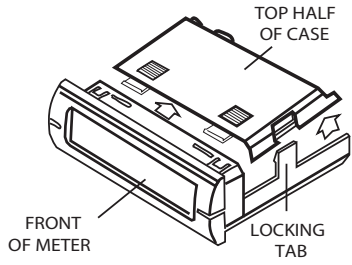

Using a screwdriver or thumbnail, spread the tabs on each side of the case to unlock the top half. Lift the rear of the top half and slide it away from the front of the meter.

Scale Adjustment:

Mini-Max indicators have limited range coarse and fine adjustments for display scaling. There are no optional connections required for these to function. The meter can be scaled down to 1/2 the value of the input, or scaled up to 1 times the value of the input, or a maximum reading of 1.9999, whichever is lower.

LCD VERSIONS

Scale Adjustment:

The "Coarse" adjustment R12 will allow a limited range of scaling values. The "Fine" adjustment R9 allows for an adjustment range of approximately 1% of the "Coarse" adjustment. Apply the full scale input to the meter. Adjust R12 to be within 1% of the desired result. Then use R9 to obtain the final desired result.

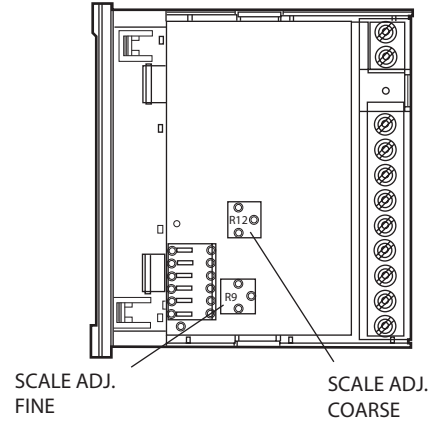

Note: Any physical damage to the meter during adjustment will void the warranty.

LED VERSIONS

Scale Adjustment:

The "Coarse" adjustment RV1 will allow a limited range of scaling values. The "Fine" adjustment RV2 allows for an adjustment range of approximately 1% of the "Coarse" adjustment. Apply the full scale input to the meter. Adjust RV1 to be within 1% of the desired result. Then use RV2 to obtain the final desired result.

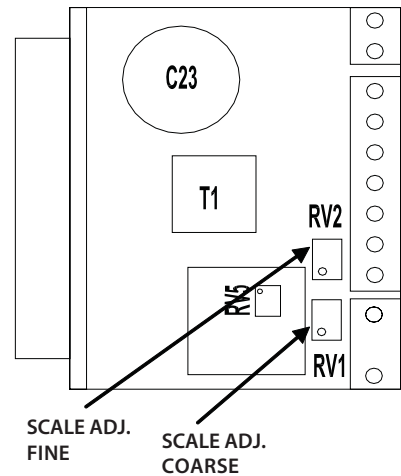

Note: Any physical damage to the meter during adjustment will void the warranty.

Stacking Features

The mounting brackets, included with every Mini-Max, can be connected together. Multiple units can be mounted in a single opening, allowing perfect alignment.

To punch one hole for multiple units, be sure to adjust the standard panel cutout dimensions as shown here; otherwise the meters will not fit properly in the hole.

Mounting multiple units is quick and easy. Install the first meter (bottom unit first if stacking vertically). Position the next mounting bracket snugly against the first one, and slide the second meter into place. Repeat for remaining units.

Vertical

Standard cutout

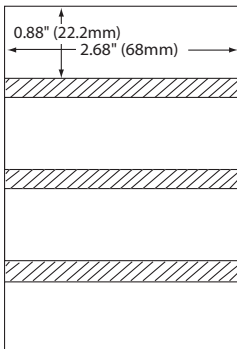

0.071" (1.8mm)
Add to standard when stacking

Vertical

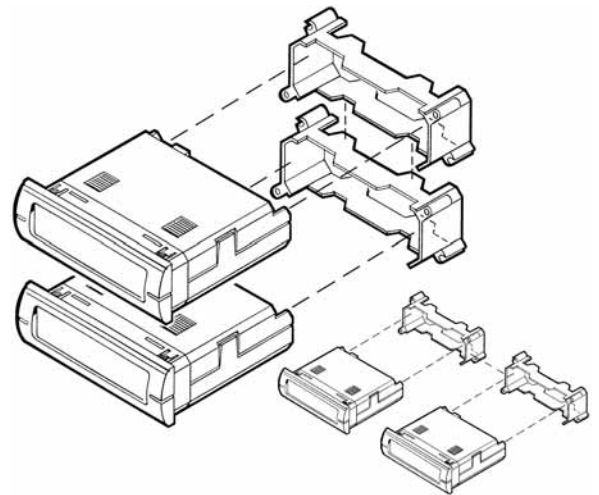

Horizontal

Standard cutout



0.16" (4.0mm)

Add to standard when stacking

Application Example

A company needs to monitor the power supply voltage (120VAC), load current (50 amps) and frequency (60Hz) of an AC motor.

Voltage: A Mini-Max 200 Volt AC meter is installed in parallel with the power supply.

Current: A Mini-Max 5 Amp AC meter is attached to a 50:5 amp Donut Current Transformer. The meter must be scaled to display 50.00 when 5 amps are applied. R9 and R12 (RV1 and RV2 LED) are adjusted until the correct value is displayed. The meter is connected to the donut, and the AC line is fed through the donut.

Frequency: A Mini-Max 200Hz Frequency meter is installed in parallel with the power supply. The wiring for the volt meter can be split to the frequency meter as long as the voltage will not exceed 200 volts AC. [Note: Frequency Meter available in model M235 LCD only]

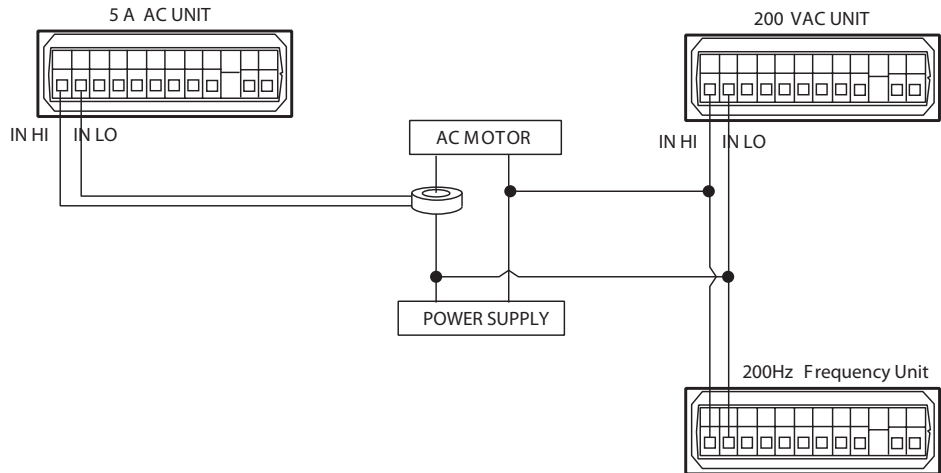

Ordering Information

Your Mini-Max Voltage Indicator can be configured by making an entry for each box

Basic Unit	Display	DPM Power Supply	Range	Excitation Output**
M245	4-1/2 Digit Indicator	0 85-250 VAC 2 9-32VDC	31 200mV 32 2V 33 20V 34 200V 35 600V*** 36 270V*	0 None 1 12VDC 2 24VDC
	0 Non Backlight (LCD) 1 Negative Image Red (LCD) 2 Red LED			

Note: LCD Display hold feature is configured at the factory and must be specified at time of order.

Note: Special scaling is available from the factory at the time of ordering.

*Not available for LED
**25mA max output
***Not available for LCD

Safety Symbols



The WARNING sign denotes a hazard. It calls attention to a procedure, practice, or the like, which, if not correctly performed or adhered to, could result in personal injury.



The CAUTION sign denotes a hazard. It calls attention to an operating procedure, practice, or the like, which, if not correctly adhered to, could result in damage to or destruction of part or all of the instrument.

Accessories

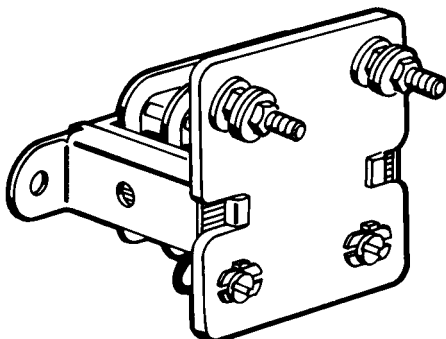

Model 186 Current Transformers easily convert an AC current signal (up to 50 Aac) into a 0-10 Vac voltage signal over a long distance. This allows remote monitoring of a process or application. If a higher current rating is desired (up to 1999 Amps), these units can be coupled with a Donut Current Transformer.

Ordering Information

Range	VA	Cat. No.
0-5 Aac	0.75	01312
0-10 Aac	1.45	01314
0-15 Aac	1.05	01315
0-20 Aac	1.04	01316
0-25 Aac	1.50	01317
0-30 Aac	1.10	01318
0-40 Aac	1.09	01319
0-50 Aac	1.90	01321
0-100mAac	0.50	01295
0-500mAac	0.53	01304